

Hyundai Robot

HR100P060301MME2



# Manipulator Maintenance Manual

- HR100P



---

**The information presented in the manual is the property of HHI.  
Any copy or even partial is not allowed without prior written authorization from  
HHI.  
It may not be provided to the third party, nor used for any other purposes.**

**HHI reserves the right to modify without prior notification.**

**Printed in Korea - Oct. 2005. 1st Edition  
Copyright © 2005 by Hyundai Heavy Industries Co., Ltd.**



# Contents

## 1. Safety ..... 1-1

1.1. Introduction .....	1-2
1.2. Relevant Safety Regulations .....	1-4
1.3. Safety Training.....	1-4
1.4. Safety Related Nameplate.....	1-5
1.4.1. Safety Marking.....	1-5
1.4.2. Safety Nameplate .....	1-6
1.5. Definition of Safety Functions .....	1-7
1.6. Installation .....	1-8
1.6.1. Safety Fence.....	1-8
1.6.2. Placement of Robot & Peripheral Equipment.....	1-10
1.6.3. Installing the Robot .....	1-12
1.6.4. Space for Robot Installation.....	1-14
1.7. Safety Operation for Robot Handling .....	1-15
1.7.1. Safety Precautions for Robot Handling.....	1-15
1.7.2. Safety Precautions for Operating Test.....	1-18
1.7.3. Safety Precautions for Automatic Operation .....	1-19
1.8. Safety Precautions for Access to Safety Fence.....	1-20
1.9. Safety Precautions for Maintenance and Repair.....	1-21
1.9.1. Safety Precautions for Hi4/Hi4a Controller Maintenance and Repair.....	1-21
1.9.2. Safety Precautions for Robot System & Manipulator Maintenance.....	1-22
1.9.3. Necessary Actions after Maintenance and Repair .....	1-23
1.10. Safety Functions.....	1-24
1.10.1. Operating a Safety Circuit.....	1-24
1.10.2. Emergency stop.....	1-26
1.10.3. Operating Speed.....	1-29
1.10.4. Connecting the Safety Devices .....	1-29
1.10.5. Restricting the working Envelope.....	1-30
1.10.6. Monitoring Function .....	1-30
1.11. Safety Related to End Effectors.....	1-31
1.11.1. Gripper.....	1-31
1.11.2. Tool / Workpiece.....	1-32
1.11.3. Pneumatic and Hydraulic Systems .....	1-32
1.12. Liabilities.....	1-33

## 2. Specifications ..... 2-1

2.1. Robot Machinery Part.....	2-2
2.2. Basic Specifications.....	2-3
2.3. Axis Identification.....	2-4
2.4. Details of Wrist Axis Attachment Surface .....	2-5

## Contents

---

2.5. Application Wiring and Inspection Wiring Diagram .....	2-6
---	-----

### **3. Instructios** .....

**3-1**

3.1. Robot Component Name .....	3-2
3.2. How to operate .....	3-4
3.3. How to Install .....	3-5
3.3.1. Operating Conditions .....	3-5
3.3.2. Installing the Robot Manipulator .....	3-6
3.3.3. Dimension of Installation Surface .....	3-7
3.3.4. Accuracy of Installation Surface .....	3-8
3.4. Allowable Load of Wrist Axis.....	3-9

### **4. Inspection** .....

**4-1**

4.1. Inspection Item and Period .....	4-2
4.2. Inspection Item and Period .....	4-3
4.3. Inspection of Main External Bolts.....	4-5
4.4. Inspecting the Wrist Posture.....	4-7
4.5. Inspection Internal Wiring .....	4-8
4.5.1. The Conditions of Safety Inspection .....	4-8
4.5.2. Inspection Part.....	4-9

### **5. Maintenance** .....

**5-1**

5.1. Grease Replenishment/Replacement .....	5-2
5.1.1. S-Axis Speed Reducer.....	5-3
5.1.2. H-Axis Speed Reducer .....	5-4
5.1.3. V-Axis Speed Reducer.....	5-6
5.1.4. T-Axis Speed Reducer .....	5-8
5.1.5. Bearing Joint Parts .....	5-9
5.2. Battery Replacement .....	5-10
5.2.1. Instructions for Battery Storage.....	5-12
5.3. Internal Wiring.....	5-13
5.3.1. Wiring Connection Diagram .....	5-14

### **6. Troubleshooting** .....

**6-1**

6.1. Troubleshooting Procedure .....	6-2
6.2. Trouble Symptoms and Possible Causes .....	6-3
6.3. Diagnostics and Resolutions for Major Parts Failure .....	6-4
6.3.1. Fulcrum Bearings.....	6-4

6.3.2. Reduction Gear.....	6-5
6.3.3. Brakes .....	6-7
6.3.4. Motor .....	6-8
6.3.5. Encoder .....	6-9
6.4. Encoder Zero Setting .....	6-10
6.4.1. Zero Setting .....	6-11
6.4.2. Zero Setting for Wrist Axis .....	6-12
6.4.3. Encoder Reset .....	6-13
6.4.4. Confirming the Reset.....	6-14
6.4.5. Encoder Calibration(Data input) and Selection .....	6-15

## **7. Recommended Spare Parts** ..... 7-1

## **8. Internal Wiring Diagram** ..... 8-1

8.1. Manipulator Configuration.....	8-2
8.2. Wiring Diagram .....	8-3

## **List of Figures**

Fig 1.1 Recommended Size for Fence and Gate Hole (Square Gate).....	1-8
Fig 1.2 Recommended Size for Fence and Gate Hole (Slot Gate) .....	1-8
Fig 1.3 Placement of Peripheral Equipment and Operator .....	1-10
Fig 1.4 Space for robot installation.....	1-14
Fig 1.5 Robot's Safety Circuit .....	1-24
Fig 1.6 Emergency Stop .....	1-27
Fig 1.7 Emergency Stop Connection of External System .....	1-28
Fig 2.1 Robot Machinery Part.....	2-2
Fig 2.2 Robot Dimension and Axis.....	2-4
Fig 2.3 Details of Wrist Axis Attachment Surface .....	2-5
Fig 2.4 Application Wiring and Inspection Wiring Diagram .....	2-6
Fig 3.1 Name of Robot Components .....	3-2
Fig 3.2 Transportation Method .....	3-4
Fig 3.3 Dimension of Robot Installation.....	3-7
Fig 3.4 Accuracy of Installation surface .....	3-8
Fig 3.5 Permitted Load Diagram for Imposed Weight of 60kg .....	3-10
Fig 3.6 Permitted Load Diagram for Imposed Weight of 100kg .....	3-10
Fig 3.7 Permitted Load Diagram for Imposed Weight of 120kg .....	3-11
Fig 3.8 Wrist Part Terminology Definition .....	3-12
Fig 4.1 Inspection Part for Main Bolts .....	4-6

## Contents

---

Fig 4.2 Posture Inspecting Direction .....	4-7
Fig 4.3 Cable Inspection Parts .....	4-9
Fig 5.1 Explains of internal wiring .....	5-14
Fig 5.2 Wiring connection diagram .....	5-15
Fig 6.1 Location of pin hole for zero setting in axis .....	6-11
Fig 8.1 Manipulator Configuration .....	8-2
Fig 8.2 Wiring connection diagram .....	8-3
Fig 8.4 Servo hand wiring Connection (Optional) .....	8-4
Fig 8.5 Encoder Wiring Connection No.1 .....	8-5
Fig 8.6 Encoder Wiring Connection No.2 .....	8-6
Fig 8.7 Application Wiring Connection .....	8-7
Fig 8.8 Application Wiring Connection No.2 .....	8-8

## List of Tables

Table 1-1 Safety marking .....	1-5
Table 1-2 State of robot stop .....	1-17
Table 2-1 Basic Specifications for Models .....	2-3
Table 2-2 Axis Motion .....	2-4
Table 3-1 Componets Name .....	3-3
Table 3-2 Allowable Payload weight .....	3-9
Table 4-1 Inspection Schedule .....	4-2
Table 4-2 Inspection Items and Periods .....	4-3
Table 4-3 Inspection part for main bolts .....	4-5
Table 6-1 Trouble phenomenon and cause .....	6-3
Table 6-2 Necessary tools and parts .....	6-10
Table 7-1 Spare Parts List .....	7-2



**1**  
**Safety**



# 1. Safety

HR100P

## 1.1. Introduction

The main purpose of this chapter is to describe the safety precautions for users and operators who repair and manipulate the industrial robot.

This manual describes safety precautions for robot manipulator and controller, in comply with the requirement of ANSI/RIA R15.06-1999, Standard for Safety, Industrial Robots, and qualified with safety regulations. The technical description and installation method of robot system is presented in detail at the specifications regarding installation of robot manipulator and controller.

Every operator, who installs, replaces, adjusts, manipulates, maintains, and repairs, must read thoroughly and fully understand the manipulation and maintenance manual, in particular, the special attention must be paid to the WARNING symbol, the most important marking related to the safety.

Installation, replacement, adjustment, manipulation, maintenance, and repair of robot system must be performed by the personnel who was duly trained for these purposes, following the indicated operating procedure.

This company is planning and carrying out the relevant training such as maintenance, repair, and manipulation for the above operations, so robot users make sure that robot operators should get the relevant training. And make sure that the robot handling work should be carried out only by the operators who completed this training course.

The Users of HR and HX industrial robots have a responsibility under the safety relevant regulations valid in the country where the robot is installed, and a responsibility to properly design, install, and operate the safety devices to protect workers.

The dangerous zone of robot system, that is the working range in which the robot, tool, and peripheral equipment are operated, must be safeguarded to prevent workers or objects from entering the zone. If a person or object should nevertheless enters the dangerous zone, make sure that the robot system is immediately shut down by emergency stop system. The operators of robot system have a responsibility to take all necessary steps to make correct installation, examination and operation of the relevant safety devices.

This manual is provided for the utilization of HR and HX Series Manipulator models and Hi4/Hi4a controller.

Valid application and invalid environment of HR and HX Series robots are as follows.

### **Application**

It is applied to the 6-axis industrial robot used by installing on the surface of wall or plane (axes addable). It is also appropriate for controlling operation in the dotted section or consecutive section.

Major application is

- Spot welding
- Handling
- Assembly
- Application such as Sealing
- MIG/MAG welding
- Palletizing
- Grinding

For the other use than the above emergency application, make a contact with our company to consult on the robot use and possible applications.

### **Invalid environment**

Our robot must not be used in a highly explosive environment and the areas contaminated by oil, flammable materials or chemical materials. (Prohibited to be installed and manipulated.)

## 1.2. Relevant Safety Regulations

The robot is designed as per ISO10218.Jan. 1992 , safety standards for industrial robots, and furthermore in comply with ANSI/RIA 15.06-1999 regulations.

## 1.3. Safety Training

All the personnel who intend to teach, operate or inspect the robot must be trained in an approved robotic operation and safety training course before start-up. The safety training course includes the following details:



- Purpose and functions of safety devices
- Safety procedure to handle the robot
- Performance of robot or the robot system and possible hazards
- Tasks associated with any specific robot applications
- Safety concepts, etc.

## 1.4. Safety Related Nameplate

### 1.4.1. Safety Marking

For the purpose of effective safety instructions, the following safety symbols are used in this manual.

Table 1-1 Safety marking

Symbols		Descriptions
Warning		Indicate a potentially hazardous situation which, if not avoided, could result in death or serious injury to personnel and damage to equipment. The special attention must be paid to the operation and handling.
Mandatory		Indicate the compulsory measures that should be performed.
Prohibited		Indicate the prohibited actions and/or operations that should not be performed.

### 1.4.2. Safety Nameplate

Identification plates, warning label and safety symbols are attached to the robot and to the inside and outside of control panel. The designation labels and cable Mark for wire harness between the robot and control panel, and the cables inside/outside of control panel are provided.

All of these plates, labels, symbols and marks constitute safety-relevant parts of the robot and the control panel. They must remain attached to the robot manipulator and control panel at their clearly visible positions all the time for the safety and their full performance.

The painted markings on the floor and signs indicating dangerous zones must be clearly distinguished in form, color, and style from other markings on the machine near the robot system or inside the plant facilities where the robot system is installed.



**It is forbidden to remove, cover, or paint over by way of spoiling the clearly visible identification plates, warning labels, safety symbols, designation labels and cable marks.**

## 1.5. Definition of Safety Functions

### **Emergency Stop Function - IEC 204-1,10,7**

There is one emergency stop button on the controller and teaching pendant respectively. If necessary, additional emergency buttons should be able to connected to the robot's safety chain circuit. The emergency stop function, which overrides all other robot controls, stops all moving parts by disconnecting power supply, and removes drive power to prevent the use of other dangerous functions controlled by the robot.

### **Safety Stop Function - ISO 10218(EN 775),6.4.3**

When a safety stop circuit is provided, each robot must be delivered with the necessary connections for the safeguards and interlocks associated with this circuit. The robot should have a number of electrical input signals which can be used to connect external safety devices, such as safety gates, safety pads, and safety lamps. These signals allow the robot's safety functions to be activated by all equipment, including peripheral equipment and the robot itself.

### **Speed Limiation Function - ISO 10218(EN 775),3.2.17**

In a manual mode, the speed of robot is strictly limited to 250 mm per second as maximum.

The speed limitation applies not only to the TCT(Tool Coordinate Time), but to all parts of manual mode robot. The speed of equipment mounted on the robot should be possibly monitored.

### **Restricting working Envelope - ANSI/RIA R15.06-1999**

The working envelope of robot axes should be restricted using software limits. Axis 1,2, and 3 can also be restricted by means of mechanical stopper.

### **Operation Mode Selection - ANSI/RIA R15.06-1999**

The robot must be operated either manually or automatically. In a manual mode, the robot must be operated only by using the teach pendant..

## 1.6. Installation

### ! 1.6.1. Safety Fence

Install safety fence against the possible collision between the robot and workers, so that no worker may approach the robot. When operators or other personnel enter the robot's working envelope by accident, it may cause an accident. Install the safety fence to stop the robot when one, who intends to replace for TIP DRESSING or TIP replacement, or to inspect welding equipment, opens the fence gate and approaches the equipment during operation.

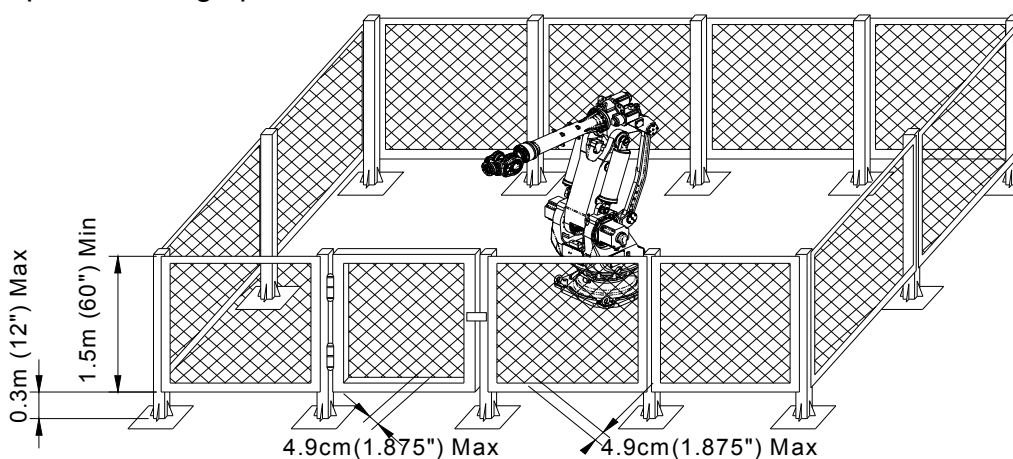

Fig 1.1 Recommended Size for Fence and Gate Hole (Square Gate)

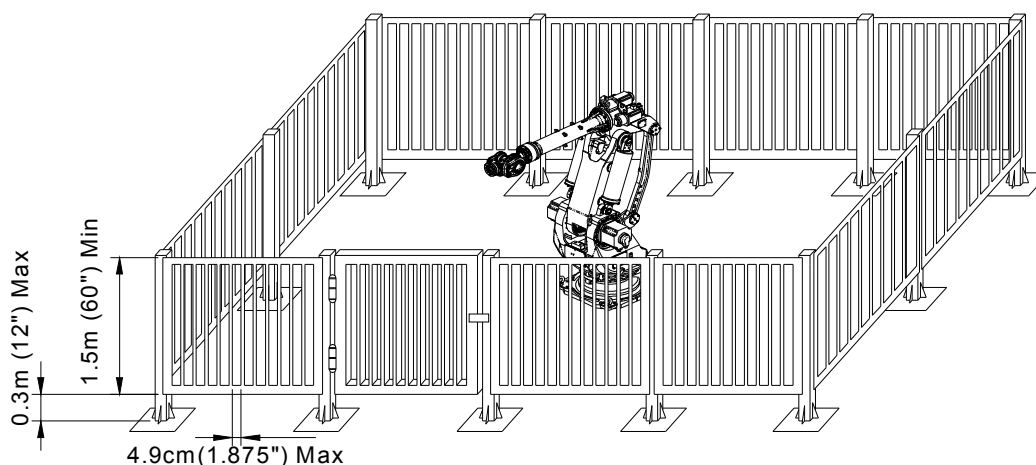

Fig 1.2 Recommended Size for Fence and Gate Hole (Slot Gate)

- ① Install the safety fence to cover the robot's working envelope and to secure enough space for teaching and maintenance working. The safety fence should also be firmly installed so that it is hardly accessible and removable.

- ② The safety fence should be a fixed type in principle, using harmless materials that do not have any broken surface or projecting part.
- ③ Install the safety fence with an entrance gate, and register the safety plug at the gate so that it does not open unless pulling the plug out. Interlock the robot to be MOTORS OFF when the safety plug is pulled out., or wire the robot to be MOTORS OFF when the safety fence is open. (Refer to “11. Various Signal Connections”, Hi4/Hi4a Controller Manual)
- ④ When intending to operate the robot with the safety plug pulled out, wire the robot as a low-speed play mode. (Refer to “11. Various Signal Connections”, Hi4/Hi4a Controller Manual)
- ⑤ For immediate emergency stop, install emergency stop button within operator’s easily accessible distance.
- ⑥ If the safety fence is not installed, install other devices substituting for the safety plug in the whole place within the robot’s working envelope, such as photoelectric switch and mat switch. These devices may stop the robot automatically when a person enters the working envelope.
- ⑦ The robot’s working envelope(dangerous zone) should be distinguished from other zones by painting its floor.

## ! 1.6.2. Placement of Robot & Peripheral Equipment

- (1) Make sure that the power supply is off before operating, when connecting the primary power of controller or peripheral equipment. There is a possible danger of electric shock because the high voltage such as 220V and 440V is used as its primary power.
- (2) Post a sign [No enter during operation] up the safety fence gate, and inform the operators of its purport.

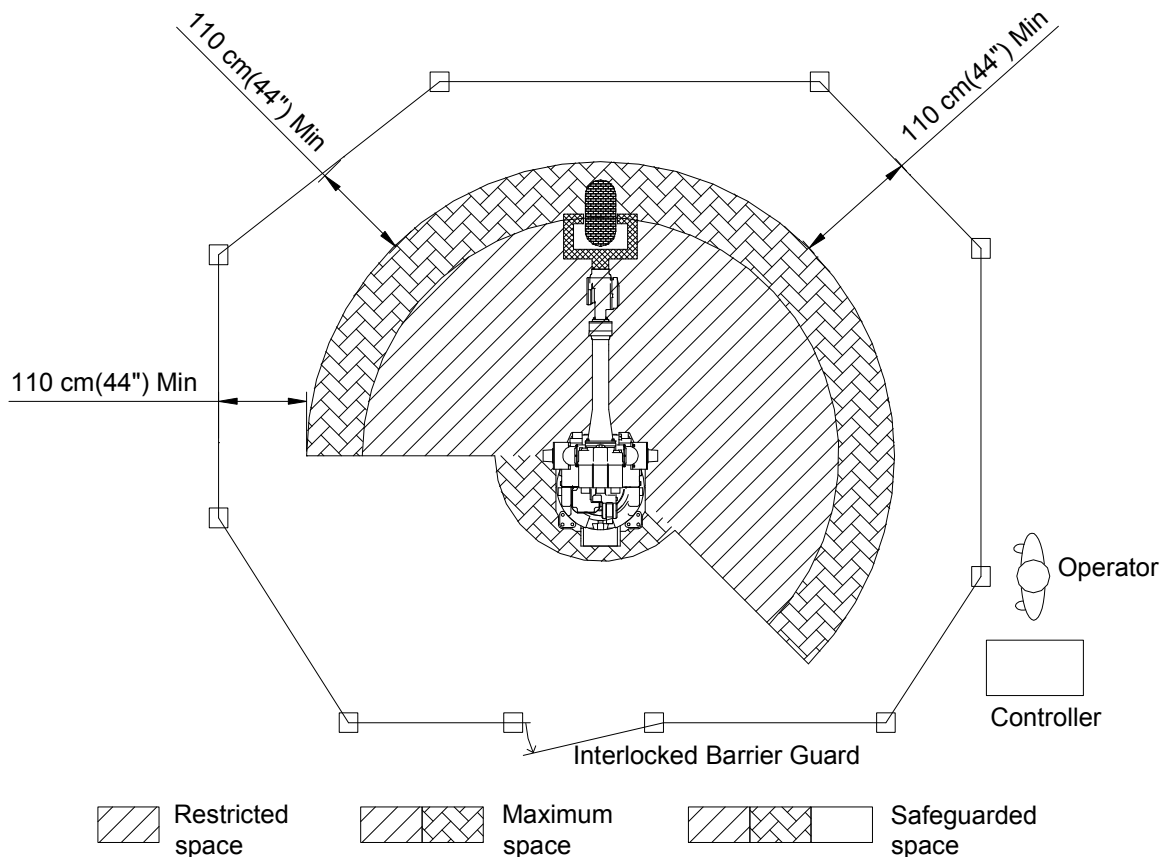

Fig 1.3 Placement of Peripheral Equipment and Operator

- (3) Arrange such devices as controller, interlock panel, and other manipulation panels to be handled outside of the safety fence.
- (4) When installing operation stand, install the emergency stop button on the stand. Make sure that the stand stops in an emergency wherever the robot is handled.

- (5) Make sure that the robot manipulator and the wiring and piping of controller, interlock panel, and timer should not be placed in the way of operator's working range so that they would not be directly stepped on by FORK and LIFT. There is a possible danger of accident if the workers are affected by electricity or the wiring is down.
- (6) Place the controller, interlock panel, and handling stand within the sight of robotic performance. It may cause a serious accident to operate the robot while the operator is working, or the robot is malfunctioning in an invisible sight.
- (7) Restrict the robot's working envelope by using soft limits and mechanical stopper if the necessary working envelope is narrower than the holding workable envelope. It is possible to stop the robot in advance when it moves beyond its normal working envelope due to an abnormal condition. (Refer to the 『Robot Manipulator Maintenance Manual』 .)
- (8) Welding spatters directly on the operator or around him may cause burning or fire. Install such devices as a glare shield or a cover in the full sight of robot's working envelope.
- (9) Make sure that the device indicating the robot's running condition whether automatic or manual mode must be noticeable even in the far distance. In the case of automatic start-up, warning with a buzzer or warning lamp is also valid.
- (10) Make sure that there is no projecting part in the robot's peripheral equipment. Cover it, if necessary. It usually may cause an accident if the operator comes in touch with it. And it may lead a serious accident if the operator is astonished at the sudden movement of robot, and conducts it.
- (11) Don't make the system designed to allow the workers to carry the Work in and out using their hands through the safety fence. It could be a cause of accident associated with compressing or amputating.

### 1.6.3. Installing the Robot

Install the robot as per the planning and layout which has been previously reviewed and studied for its optimized performance and functionality. In case of poor conditions for robot installation, the serious problems can take place, including error of relative position between robot and workpiece during operation, bad performance quality of robot caused by vibration, shortening lifetime, and cause of serious accidents. Thus, pay attention to the following precautions when installing the robot.

#### **General Safety Precautions**

- (1) Design and install the robot system properly in compliance with laws, regulations, and safety requirements valid in the country where the robot system is installed.
- (2) All the workers for the robot system must have the complete knowledge on the information specified in the application and supplementary manual, and proficiently operate and handle the industrial robot.
- (3) Installation workers of robot must follow the safety instructions and apply them to the installation when they face any safety problems.
- (4) System provider must ensure that all the circuits utilizing safety functions perfectly perform in a safe way.
- (5) Install main power supply to be disconnected from outside of the robot's working envelope.
- (6) System provider must ensure that all the circuits utilizing emergency stop function perfectly perform in a safe way.
- (7) For the immediate emergency stop, install emergency stop button within the accessible distance for the operator.

#### **Technical Safety Precautions**

- (1) Eliminate any interference with peripheral equipment considering the dimension and working envelope.
- (2) Avoid such places for installing which is directly exposed to the sun, extremely humid, contaminated by oil or chemicals, and containing a large amount of metal powder and explosive gas.

- (3) Install at the ambient temperature ranged 0~45°C.
- (4) Secure sufficient space for the easier disassembly and maintenance.
- (5) Install safety fence with a gate, and prohibit any person from entering the robot's working envelope.
- (6) Remove any obstacles out of the robot's working envelope.
- (7) Take a special measure, considering thermodynamics of controller, if the robot is installed near the heating elements or places exposed directly to the sun.
- (8) Take a special measure if the robot is installed in a place of abundant dust such as metal powder in the air.
- (9) Install the robot not to transmit welding electric current. (In other word, insulate SPOT GUN with/from the robot's wrist.)
- (10) Grounding is very critical in preventing electric shock and malfunction caused by noise, and thus install as following instructions.
  - ① Install an exclusive grounding terminal using class 3 or higher. (For the input voltage of 400V of higher, use special class 3 or higher.)
  - ② Connect grounding line into the grounding bus-bar inside of the control panel.
  - ③ In case of direct grounding on the floor by anchoring, two-point grounding both by robot manipulator and by controller can produce a "ground loop" and contrariwise cause abnormal operation. In this case, connect the grounding line to the base of robot manipulator and disconnect the second grounding point to the controller. If the robot vibrates even after stopping, double-check the grounding status because the possible main causes could be an incomplete grounding or "ground loop" .
  - ④ In the use of internal transgun(GUN), there is a possible danger of dropping because the primary power cable is directly connected to the spot gun. In this case, directly connect the grounding line to the base of robot manipulator in order to prevent any electric shock and protect the control panel, but do not connect it to the controller.

### 1.6.4. Space for Robot Installation

Install robot after securing sufficient space for maintaining the robot manipulator, Hi4/Hi4a controller, and other peripheral equipment. Install the robot manipulator and controller, securing space for installation as per the guideline as described in the figure below. Install Hi4/Hi4a controller outside of the safety fence in order to monitor the robot manipulator and to operate in a safe way.

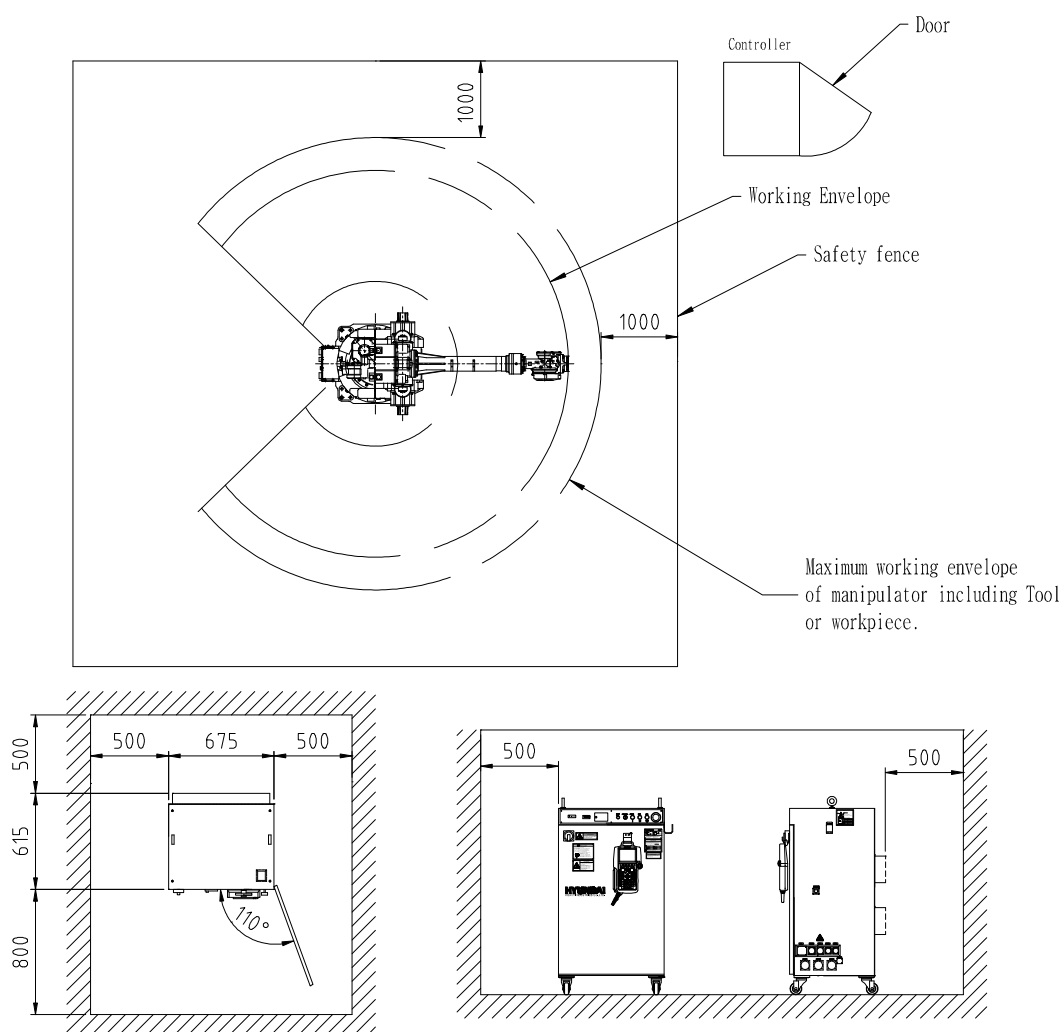

Fig 1.4 Space for robot installation

When installing, be sure to make it easier to perform the maintenance when opening the Hi4/Hi4a Controller door. Secure the available space. The controller power in the above Figure could change depending on the kind of controller.

## 1.7. Safety Operation for Robot Handling

Follow the safety instructions to prevent any accidents. Don't modify nor ignore safety devices or circuits at any time, and be careful of electric shock.

All the normal operations in an automatic mode must be performed outside of the safety fence. Check the robot's working envelope if anyone is inside before operating.

### 1.7.1. Safety Precautions for Robot Handling

- (1) Do not handle the robot other than such personnel as operators handling the robot and other possible operators and supervisors who were designated as whom duly trained in an approved robotic training course and become familiar enough with the proper operation of the safety and robotic functions.
- (2) Be sure to wear helmets, goggles, and safety shoes.
- (3) Perform the work in pairs. One person must be ready to press the emergency stop button in an emergency while the other must perform his work quickly but carefully within the robot's working envelope. Always check the escape route before working.
- (4) Make sure that there is no one in the working envelope when the power source is on.
- (5) Operations such as teaching must be performed outside of the robot's working envelope. However, if the operation is performed within the working envelope after stopping the robot, enter the envelope with safety plug or key switch for converting to automatic mode. Make sure that other operators do not change it into automatic mode by accident. Also, pay close attention to the specific direction of robotic movement in case of abnormal operation and malfunction.
- (6) Supervisors should follow the instructions below.
  - ① Be located at a place where you could take an entire view of robot, and commit yourself to monitoring.
  - ② Press the emergency stop button immediately when abnormality is found.
  - ③ Anyone is forbidden to be near the operating area other than those who are engaged in the operation.
- (7) In a manual mode, the speed of teaching is limited to 250mm/sec

- 
- (8) In teaching, post a sign [Under Teaching].
  - (9) Operators must pull the safety plug out, and enter the safety fence with the plug.
  - (10) Do not use any devices causing noise in and around the teaching area.
  - (11) Handle the teaching pendant button, while checking the teaching point with your naked eyes, and do not handle it just relying on your sense.



- (12) Do not work with your back against the robot, and always pay attention to the robot's movement.

- (13) In teaching, check and examine carefully under your feet. In particular, in high teaching for more than 2M, secure a safe zone on which you may step before teaching.



- (14) Instructions for any abnormal operations.

- ① Press immediately the emergency stop button when any abnormal operations are found.
- ② Be sure to check if the relevant equipment is stopped when checking the abnormality in an emergency stop.
- ③ In case that the robot stops automatically due to power failure, investigate possible causes and take actions after confirming that the robot completely stops.
- ④ In case of malfunction of emergency stop devices, immediately disconnect the main power and investigate possible causes to take necessary actions.
- ⑤ Investigation of the failure must be conducted only by a designated person. For the re-operation after emergency stop, operators must clarify the cause of failure and take necessary actions, and then operate the robot again following the proper procedure.

- (15) Write out the operating rules proper to working details and installing location regarding the operation and handling method for the robot, and the necessary actions for robot's any failure. In addition, it is recommended to operate the robot in accordance with the operating rules.

- (16) Instructions when the robot stops

Make sure not to approach the robot even when it seems to be stopped. Most accidents occur from a sudden movement of robot which seemed to be stopped when one approaches it. The conditions that the robot stops is as follows.

Table 1-2 State of robot stop

No.	State of Robot	Drive Power	Access
1	Pause (Minor failure, Pause switch)	ON	X
2	Emergency stop (Major failure, Emergency stop switch, Safety gate)	OFF	O
3	Input signal standby of peripheral equipment (START INTERLOCK)	ON	X
4	Playback Completion	ON	X
5	Standby	ON	X

Even in the accessible state of robot, be watchful against any possible sudden movement of robot. Make sure to avoid approaching the robot without precautions for emergency under all circumstances.

- **Though the access during a pause is shown in the table as 「x」, allow the access to robot with the same precautions as teaching work if the entrance is open to take actions for minor failures(i.e. malfunction caused by failure in arc, nozzle contact and weldment detection).**

(17) Clean up any split oil, tools, and impurities in the safety fence after completing robotic operation. Accidents such as conduction may occur in the working envelope contaminated by oil, or scattered tools on its floor. Make a habit of organizing and cleaning things up.

## 1.7.2. Safety Precautions for Operating Test

In case of operating test, errors in design or teaching and inferiority in manufacturing are possibly seen in the entire system such as teaching program, jig, and sequence. Thus, be more careful and safe in case of operating test. Accidents may occur by these combined causes.

- (1) Before handling, check the stop buttons and signal functions to stop the robot such as emergency stop button or stop button. And then, check the abnormality - detective movements. Above all, it is the most critical to check all the stop signals. It would be the most important to stop the robot when any possible accidents are predicted.
- (2) In case of operating test, start the robot at low speed (approximately 20%~30%) in the variable speed function, and repeat it more than one cycle to check the movements. If any errors are found, immediately correct them. After then, increase in speed (50% → 75% → 100%) gradually, and repeat more than one cycle respectively to check the movements. Operating at high speed from the very beginning may cause a serious accident.
- (3) In case of operating test, it is hard to predict what problems would happen. Do not enter the safety fence during operating test. Unexpected accidents are likely to occur because of its low reliability.

### 1.7.3. Safety Precautions for Automatic Operation

- (1) While posting a sign [Do Not Enter During Operation] up the safety fence gate, ask the operators not to enter during operation. If the robot stops, you may enter the safety fence under your full understanding of the situation.



- (2) Be sure to check if any operators are inside of the safety fence when starting the automatic operation. Operating without checking the presence of operators may cause a personal injury.

- (3) Before starting the automatic operation, check and confirm that the program number, step number, mode, and starting selection are in the possible state for automatic operation. If starting with the other programs or steps selected, the robot could move in an unpredicted way, and lead to an accident.

- (4) Before starting the automatic operation, check if the robot is properly located to get started. Check whether the program number or step number is identical with the location of robot. Even if it's all identical, accidents are still possible to occur due to an abnormal movement when the robot is differently located..

- (5) Be prepared to immediately press the emergency stop button when starting the automatic operation. Immediately press the emergency stop button in case of robot's unexpected movements or emergency.

- (6) Be sure to detect any abnormalities by checking the route, condition, or sound of robot movement. Sometimes the robot may be abnormally operated including a sudden break down. However, it will show(give) a certain indication before the break down. Understand the robot's normal condition well in order to catch the symptom in advance.



- (7) When any abnormality is detected from the robot, immediately stop and take proper actions on it. Using the robot before any proper actions taken may cause an interruption of produce as well as serious failure leading to a very serious personal injury.



- (8) When checking the robot's movement after the proper actions taken for the abnormality, do not operate the robot with operators inside of the safety fence. Unexpected accidents are possibly to occur because its low reliability may cause another abnormality.



## 1.8. Safety Precautions for Access to Safety Fence

Robots are very powerful and heavy even at its low speed. When entering the safety fence, one must observe the relevant safety regulations of its pertinent country.

The operators always must be aware of the unexpected movements of robot. Robots are able to move fast shortly after being stopped. The operators should know that the robot is able to move in a different route, without any notice, by means of external signals. Thus, when trying to stop the robot during teaching or operating test, one should be able to stop the robot with a teaching pendant or control panel.

When entering the working envelope through the safety gate, take the teaching pendant with you so that other people may not operate the robot. Make sure to post up the control panel a sign indicating the state of robot handling.

Read carefully and be aware of the follows when entering the working envelope.

- (1) Do not enter the working envelope other than teaching person.
- (2) Be sure to set the 'handling setting' on teaching pendant to TEACHING LOCK.
- (3) Operation set-up mode of controller must be a manual mode in the control panel.
- (4) Always wear the approved working suite.(Do not wear a loose clothes as you please)
- (5) Do not wear gloves when handling Hi4/Hi4a controller.
- (6) Do not leave innerwear such as underwear, shirts, or necktie out of the working suite.
- (7) Do not wear personal accessories such as big earrings, rings, or necklaces.
- (8) Make sure to wear safety shoes, helmet, and goggles and if necessary, wear other self-protective outfit such as safety gloves.
- (9) Make sure that the emergency stop circuit is working correctly and in its proper function, turns MOTORS OFF when pressing the emergency stop button in the control panel and teaching pendant before handling the robot.
- (10) Make your posture face-to-face with the robot manipulator when performing your work.
- (11) Follow the predetermined working procedure.
- (12) Be prepared for emergency exit or safe place considering that the robot may unexpectedly rush at you.

## 1.9. Safety Precautions for Maintenance and Repair



### 1.9.1. Safety Precautions for Hi4/Hi4a Controller Maintenance and Repair

- (1) Maintenance and repair of the robot must be performed by the personnel who was duly trained in the special maintenance training course and has a good knowledge of maintenance.
- (2) Perform your work following the maintenance procedures for controller.
- (3) Perform your maintenance and repair in a safe way by securing emergency exit or safe place.
- (4) Before the daily maintenance, repair, or changing parts, be sure to power down. In addition, post a warning sign [Do Not Input Power] up the primary power so that other operators may not input power by accident..
- (5) When changing parts, be sure to use the specified ones.
- (6) Be sure to power down when opening the Hi4/Hi4a controller door.
- (7) Before performing, wait for three minutes after power down.
- (8) Do not touch the heat sink and regeneration resistor of servo amp because they generate an intense heat.
- (9) After completing maintenance, Be sure to close the door completely after checking if tools or other things are still remained in the Hi4/Hi4a controller.

### 1.9.2. Safety Precautions for Robot System & Manipulator Maintenance

- (1) Refer to the safety precautions for Hi4/Hi4a controller maintenance and repair.
- (2) Perform your maintenance and repair for the robot system and manipulator, following the indicated procedures.
- (3) Be sure to disconnect the primary power of controller. Post the warning sign [Do not input power] up the primary power to prevent other workers from connecting the power.
- (4) Make sure that the Arm is fixed and immovable before maintenance and repair since dropping or moving of the robot's Arm may cause a danger during maintenance and repair. (Refer to the 『Robot manipulator maintenance manual』 .)



### **1.9.3. Necessary Actions after Maintenance and Repair**

- (1) Check if the cables or parts of controller are properly connected.
- (2) After maintenance is completed, carefully check that no tools are left around or inside of the controller and manipulator. Make sure that the door is firmly closed.
- (3) Do not turn on the power if any problems or critical failures are detected.
- (4) Be sure that there is no one within the working envelope, and that you are in a safe place before turning on the power
- (5) Turn on the main circuit breaker on the control panel.
- (6) Check the current position and status of robot.
- (7) Operate the manipulator at low speed.

## 1.10. Safety Functions

### 1.10.1. Operating a Safety Circuit

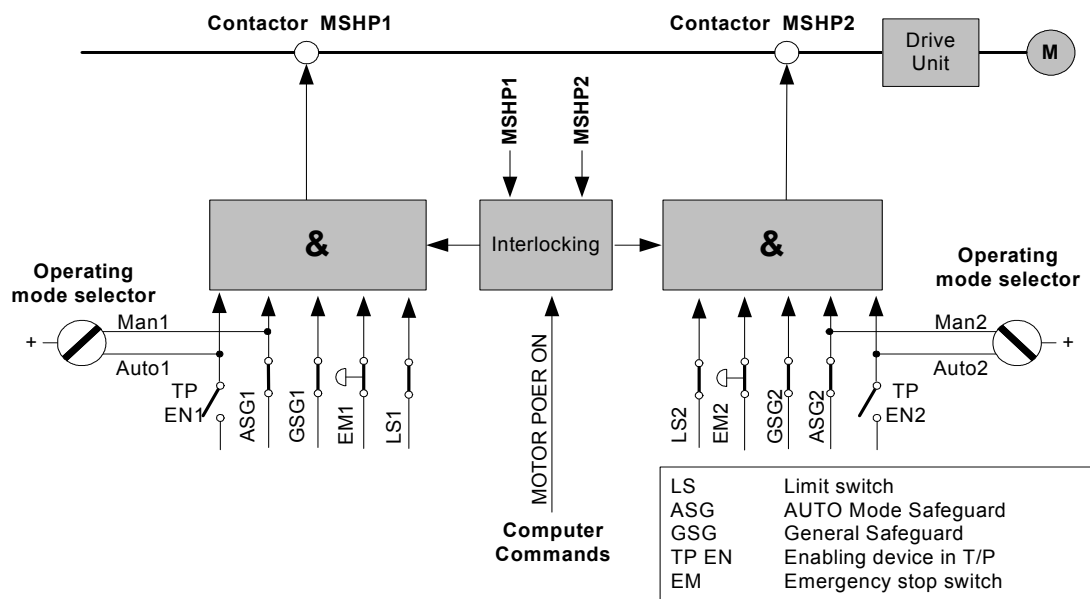

Fig 1.5 Robot's Safety Circuit

The robot's safety system is based on a two-channel safety circuit that is continuously monitored. If an error is detected, the power supply to the motors is disconnected and the motor brake is applied. To return the robot to MOTORS ON mode, the switches of two-channel circuit must be connected. If one of the two-channel circuit switches shorts, the contactor of motor will be disconnected leading to the application of brake, and finally the robot will be stopped. Furthermore, when safety circuit is disconnected, the interrupting call will be sent automatically to the controller to find out the possible reason for the interruption.

The safety control circuit of operation is based on dual safety electric circuit in which the controller and MOTORS ON mode are operated interactively. In order to be in MOTORS ON mode, the safety circuit consisted of several switches must be all connected. MOTORS ON mode indicates that drive power is supplied to the motors. If one of the contactors is disconnected, the robot will always return to MOTORS OFF mode.

MOTORS OFF mode indicates that drive power is removed from the robot's motors and the brakes are applied. The status of the switches is displayed on the teach pendant. (Refer to the I/O monitoring screen of "SERVICE" menu, 『Hi4/Hi4a controller operation manual』 .)

### Safety circuit

The emergency stop buttons on the controller panel and on the teaching pendant and external emergency stop buttons are included in the safety circuit of operation. Users may install the safety devices (safety plug, safety stop device for safe place) which are operated in the AUTO mode. In a manual mode, the signals of these safety devices are ignored. You can connect the general safety stop devices that is active in all operating modes. No one can enter the working envelope in an automatic operation mode due to the unconditional operation of the safety devices (door, safety mat, safety plug etc.). These signals are also generated in a manual mode, but the controller will keep the robot operating while ignoring the robot's teaching. In this case, maximum speed of robot is restricted to 250mm/s. Thus, the purpose of this safety stop function is to secure the safe area around the manipulator while one approaches the robot for maintenance and teaching.

When the robot is stopped by a limit switch, it can be moved from the position by jogging it with the operation key on the teaching pendant. (Refer to "constant setting", 『Hi4/Hi4a controller operation manual』 .)



**The safety circuits must never be by-passed, modified or changed in any way.**

## 1.10.2. Emergency stop

An emergency stop should be activated when people or equipment is located at the dangerous area. The emergency stop buttons are located both on the control panel and on the teaching pendant.

All safety control devices such as emergency stop buttons on the control panel must be located outside the working envelope and easily accessible at any time.

### Status of Emergency stop

When the button is pressed, the robot will operate as follows.

Robot stops immediately in any cases.

- Disconnect the servo system power.
- Motor brake is activated
- Emergency stop message is displayed on screen.

For the emergency stop, the following two methods can operated simultaneously.  
(Emergency stop for control panel and teach pendant is basic)

**(1) Emergency stop for control panel and teach pendant (Basic)**

The emergency stop switch is on the control panel and teach pendant of the controller.

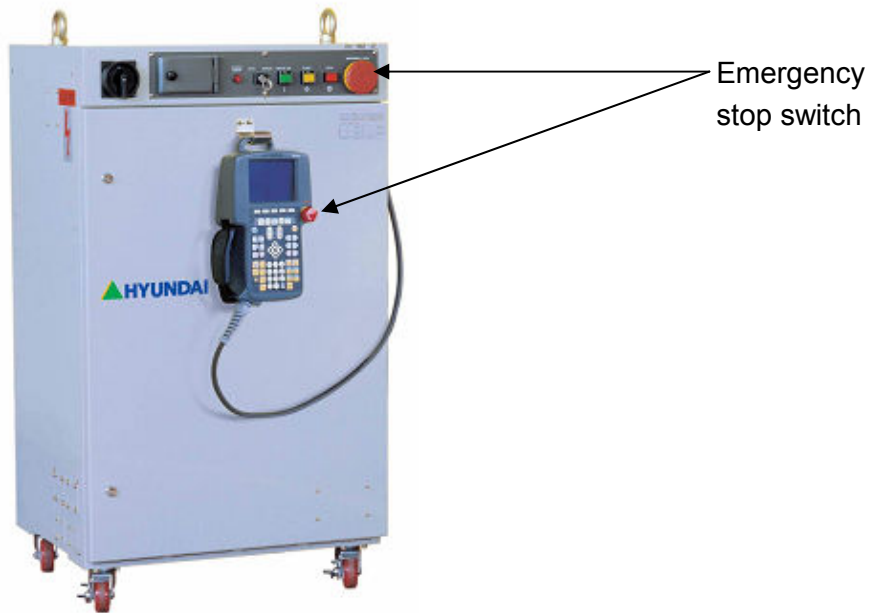

Fig 1.6 Emergency Stop

**(2) Emergency stop of external system**

External emergency stop device (button etc.) can be connected to the safety electric circuit in accordance with applied standard for the emergency stop circuit.

▶ Emergency stop connection of the external system

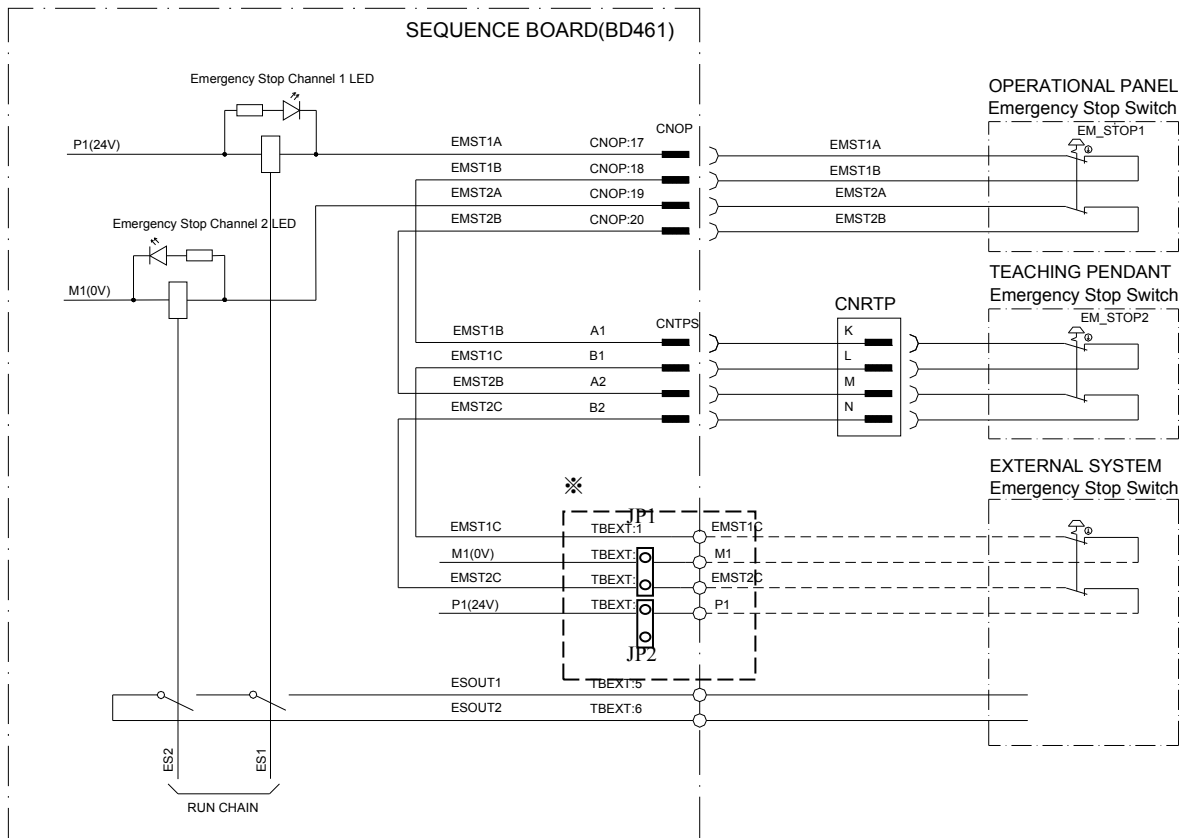

Fig 1.7 Emergency Stop Connection of External System

※ When using the emergency stop of the external system, connect the Terminal No. 1 (ES1) & No. 2 (M1,0V Common) or No. 3 (ES2) & No. 4 (P1,24V Common) of the terminal block of BD461 to the external emergency stop line, and you must open JP1 or JP2.

At this time, the emergency stop must be connected to be Normal On and it must be check for proper operation during test run.

### **1.10.3. Operating Speed**

To teach the robot, the operating mode switch must be in a MANUAL mode. Then the maximum speed of robot is limited to 250mm/s..

### **1.10.4. Connecting the Safety Devices**

External safety devices such as light beams, light curtains, safety plug, and safety mats which can be adapted by the system builder execute interlocking the controller by way of connecting with safety circuit within the controller. These devices are used for safety device during execution of normal program in an automatic mode.

### 1.10.5. Restricting the working Envelope

When the robot is not necessary to reach certain area for specific applications, working envelope of the robot can be limited to secure the sufficient safety working area. This will reduce the damage or loss in case of robot's collision with external safety devices such as safety fence, etc.. The movement of axes 1,2, and 3 of HR, HX can be limited by means of mechanical stopper or electrical limit switches. In this case, the corresponding software limitation parameters must be also changed. The movement of the three wrist axes, if necessary, can be also limited by the Main CPU. Limitation of working envelope for all the axes could be carried out by the user. The robot is delivered to customer as the status of full working envelope setting.

**Manual mode: Maximum speed is 250mm/s..**

In a manual mode, by means of worker's selection, workers may enter the safeguarded area.

**Auto mode: The robot can be operated via remote controller.**

All safety devices such as safety door, safety mats, etc. are activated.  
No one may enter the safety device area of robot.

### 1.10.6. Monitoring Function

- (1) Motor monitoring function  
Motors are protected against overload by means of onboard sensors.
- (2) Voltage Monitoring Function  
For the protection of, the servo amp module turns off the power switch when the voltage is too low or too high.

## 1.11. Safety Related to End Effectors

### 1.11.1. Gripper

- (1) When a gripper is used to grip a workpiece, there should be safety precautions for unexpected dropping of the loaded workpiece.
- (2) When any end effectors or devices are installed on the robot arm, use the required size and piece of bolt, and securely fasten as per the required torque using torque wrench. Do not use the bolt which has rust or dirt on its surface..
- (3) End effector must be designed and manufactured not to exceed the maximum allowable load at the wrist of robot. Even though power or air supply stops, the gripped workpiece must not be dropped from the gripper. In order to remove any risks and problems which may cause personal injury and/or physical damage, the sharp edge and projecting part of end effector must be made dull and smooth.

### **1.11.2. Tool / Workpiece**

- (1) It must be possible to replace tools such as milling cutters in a safe manner. Make sure that safety devices are working correctly until the cutters stop rotating.
- (2) Grippers must be designed to keep in gripping workpiece securely even though a power failure or a control failure takes place. It must be possible to release workpiece from the gripper in a manual mode.

### **1.11.3. Pneumatic and Hydraulic Systems**

- (1) The special safety regulations will apply to pneumatic and hydraulic systems. .
- (2) Since residual energy of pneumatic and hydraulic systems can be still remaining even after the robot stops, particular care and attention must be paid by users. Internal pressure of equipment must be removed whenever starting the repair work for pneumatic and hydraulic systems.

## 1.12. Liabilities

The robot system has been built in accordance with the latest technical standards and approved safety rules. Nevertheless, the serious accidents such as death or personal injury still may take place due to the collision between the robot system and peripheral equipment.

The robot system must be used by operator who has a full technical knowledge on its designated use and also pay his close attention to the possible dangers and risks involved in its operation. The use of robot system is subject to compliance with these operating instructions and the operation and maintenance manual supplied together with the robot system. The safety related functions of robot system must not be used for any purposes other than safety.

When you use the robot system for any other or additional purposes than its designated usage, you must review whether it is valid in accordance with design criteria. The manufacturers cannot take any responsibility for any damage or loss which resulted from such misuse or improper use. The users shall have the full responsibility for the risks caused by such misuse or improper use. When you use and operate the robot system for its designated use, you must have a good command of all the information contained at these operating instructions as well as the maintenance manual.

The robot system may not be put into operation until it is ensured that the functional machine or plant) into which the robot system has been integrated conforms to the specifications of the EC directives 89/392 EWG dated 14 June 1989 and 91/368 EWG dated 20 June 1991.

The following harmonized standards in particular were taken into account with regard to the safety of the robot system.

- IEC 204-1,10.7
- ISO 11161,3.4
- ISO 10218(EN 775),6.4.3
- ISO 10218(EN 775),3.2.17
- ISO 10218(EN 775),3.2.8
- ISO 10218(EN 775),3.2.7

Users must take the full responsibility for any accident caused by their negligence or non-observance of these instructions. The manufacturer will not take any liabilities and responsibilities for any damages or losses caused by the misuse or malfunction of such equipment which is not included in the contract between manufacturer and user and provided by user, or such equipment which is installed around the robot system arbitrarily by the user. User must take the full liabilities and responsibilities for any risks and damages caused by such equipment.



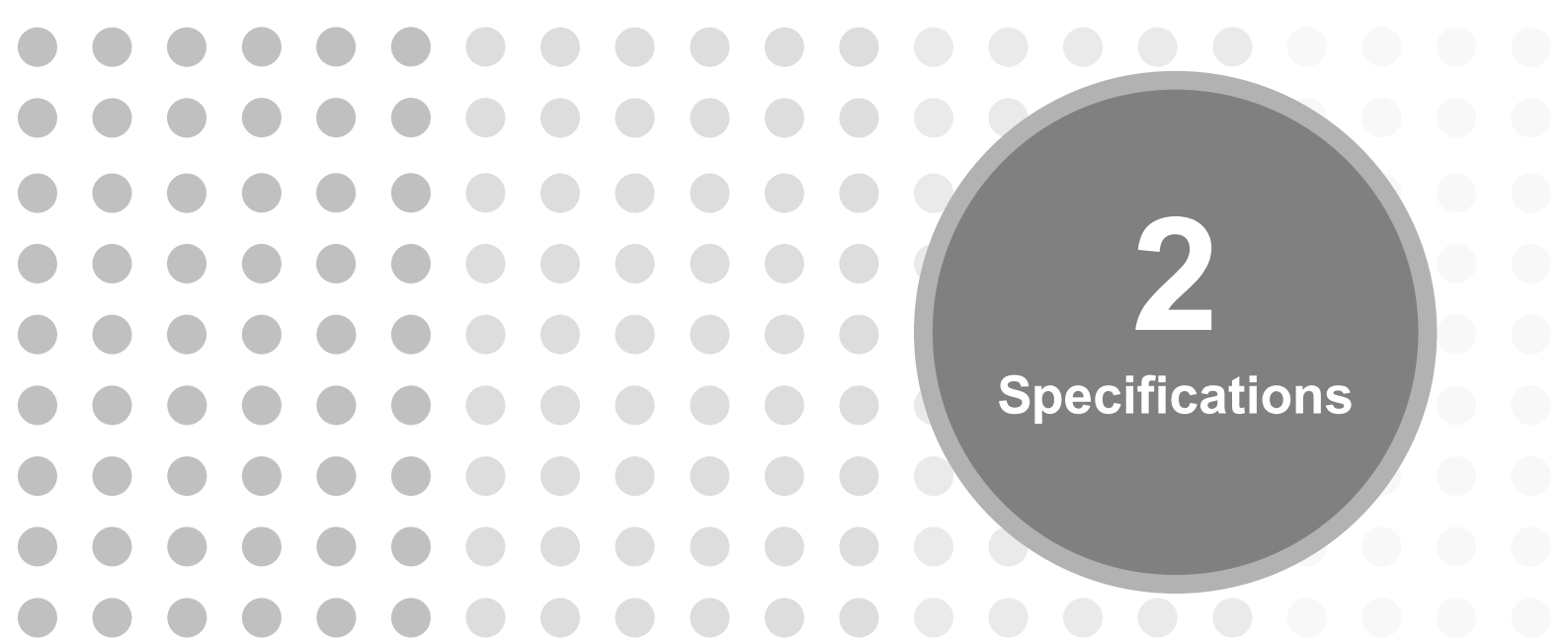

**2**  
**Specifications**



## 2. Specifications

HR100P

### 2.1. Robot Machinery Part

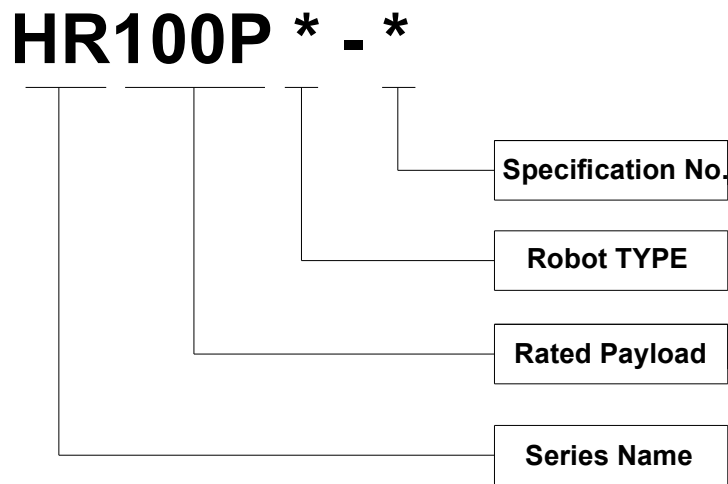

Fig 2.1 Robot Machinery Part

## 2.2. Basic Specifications

Table 2-1 Basic Specifications for Models

Item		Specification		
Construction		Articulated		
Degree of freedom		4 (Max 6.)		
Drive system		AC servo system		
Load Capacity		60 kg	100kg	120 kg
Capacity	(Cycle/Hr)	1,156	1,090	1,047
	*Note	This Capacity is variable by the layout & workpiece		
Max. Working envelope	Swivel(S)	± 160°		
	Motion Range(mm <sup>2</sup> )	□ 1200	H 2,510 mm	
		□ 1300	H 2,352 mm	
		□ 1600	H 1,177 mm	
Wrist (T=R2)		± 360°		
Wrist Torque		392 N· m (40Kgf· m)		
Accuracy of position repeatability		±0.5 mm		
Ambient Temperature		0~ 45℃ (273~318 K)		
Relative humidity		20 ~ 80 %RH		
Robot's Weight		1,200 Kgf		
Storage capacity		8,000 POINTS		
Input power		AC220V±10%, 3Φ, 50/60 Hz, 9 KVA max.		
Controller's Size		W660×H568×D575		

## 2.3. Axis Identification

Table 2-2 Axis Motion

Axis Name	Operation	Teaching Pendant Button	
<b>S</b>	Swivel	LFT(S+)	RHT(S-)
<b>H</b>	Forward and Backward	FWD(H+)	BWD(H-)
<b>V</b>	Upward and Downward	UP(V+)	DOWN(V-)
<b>R2(=T)*</b>	Wrist Rotation2	Rx+(R2+)	Rx-(R2-)

\* R2-axis of Teaching Pendant is T-axis of Robot body.  
B, R1-axis of Teaching Pendant is optional item

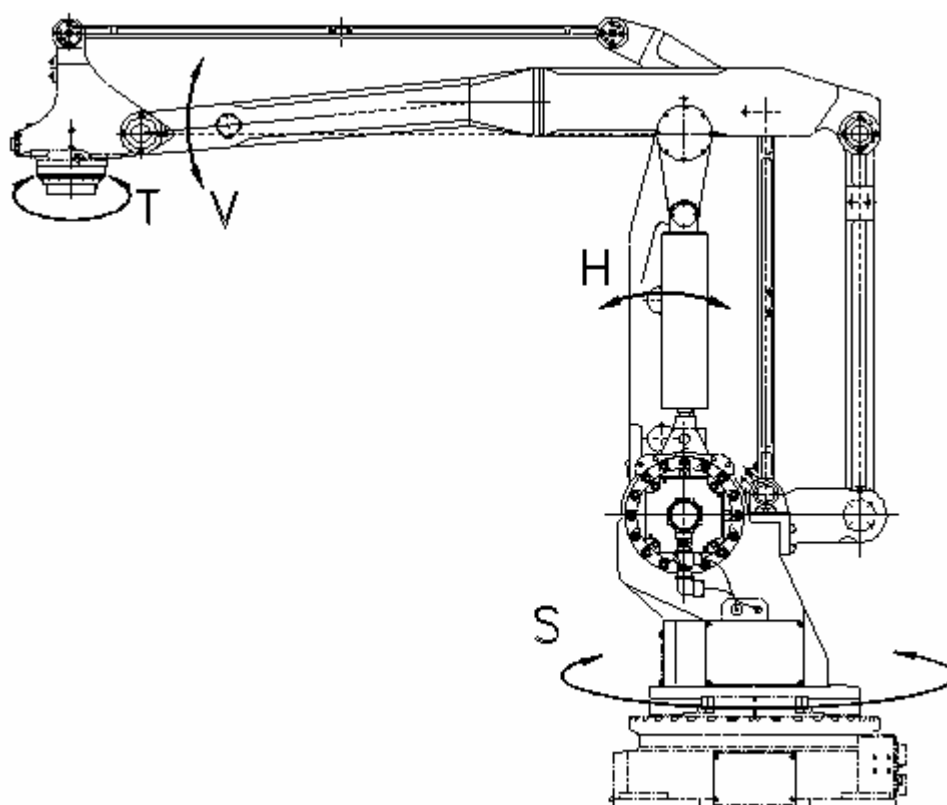

Fig 2.2 Robot Dimension and Axis

## 2.4. Details of Wrist Axis Attachment Surface

When attaching the operating tool to the mechanical interface of robot's wrist flange, fasten it with a bolt at P.C.D. 125.

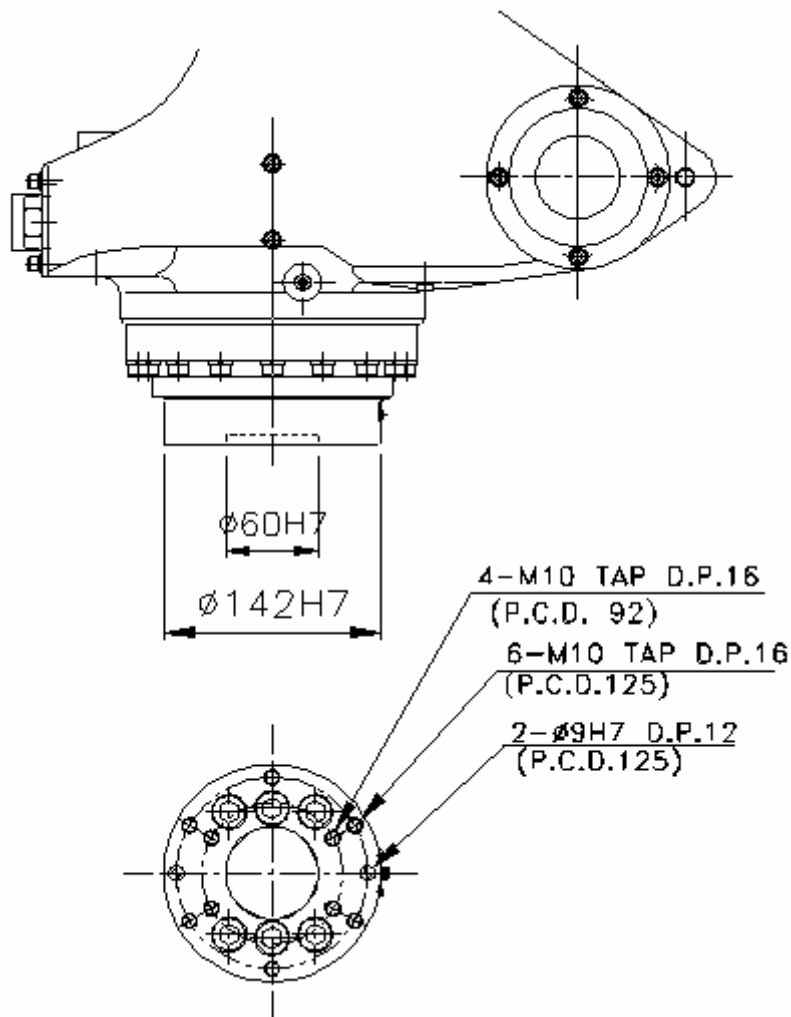

Fig 2.3 Details of Wrist Axis Attachment Surface





**3**

**Instructions**



## 3.1. Robot Component Name

The following [Fig 3.1] and [Fig 3.2] show and name each component of the robot.

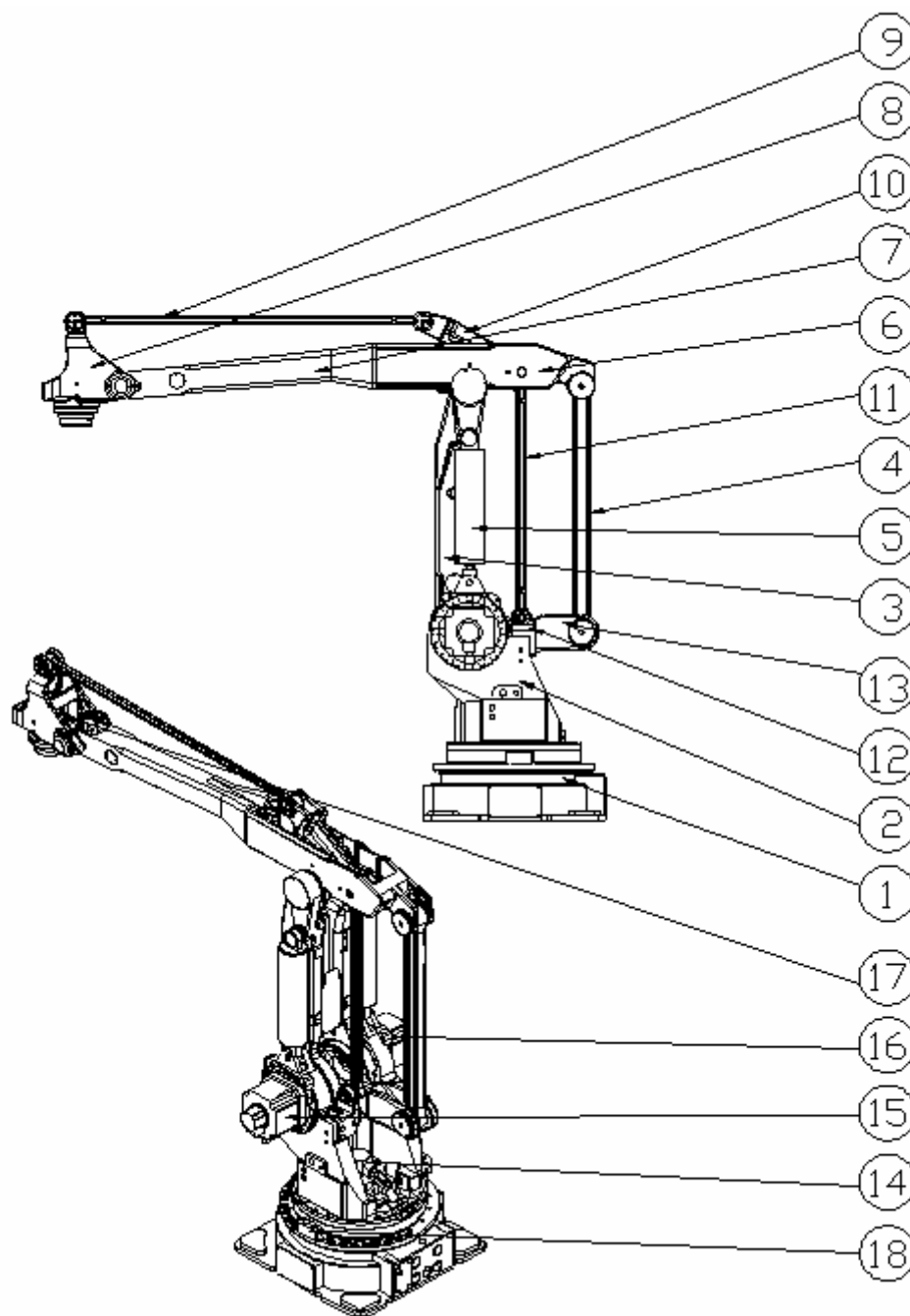

Fig 3.1 Name of Robot Components

Table 3-1 Componets Name

NO	Componets Name		Remark
1	BASE FRAME ASS'Y	B-FRAME	
2	SWING FRAME	S-FRAME	
3	HORIZONTAL ARM	H-ARM	
4	VERTICAL LINK	V-LINK	
5	BALANCE SPRING	B/S	
6	VERTICAL FRAME	V-FRAME	
7	VERTICAL ARM	V-ARM	
8	WRIST BODY	W-BODY	
9	TOP LINK	T-LINK	
10	CENTER - LINK	C-LINK	
11	REAR - LINK	R-LINK	
12	REAR LINK BRACKET	R-BRK'T	
13	HINGE	HINGE	
14	SWING AXIS MOTOR	S - AXIS MOTOR	
15	HORIZONTAL AXIS MOTOR	H - AXIS MOTOR	
16	VERTICAL AXIS MOTOR	V - AXIS MOTOR	
17	TOOL AXIS MOTOR	T - AXIS MOTOR	R2-Axis
18	SWING AXIS STOPPER	S - AXIS STOPPER	

### 3.2. How to operate

- Use the crane to transport the main unit of the robot.
- For the transportation method, first set the robot in position as shown in Fig. 3-2 and then fix 4 M24 I bolts to the base and use the 4 wires.
- For the wire, use 4 wires with the length of 3.5m and use the protection hose for the part that contacts the robot.
- Please refer to Fig. 3-2 for parts to use the protection hose.

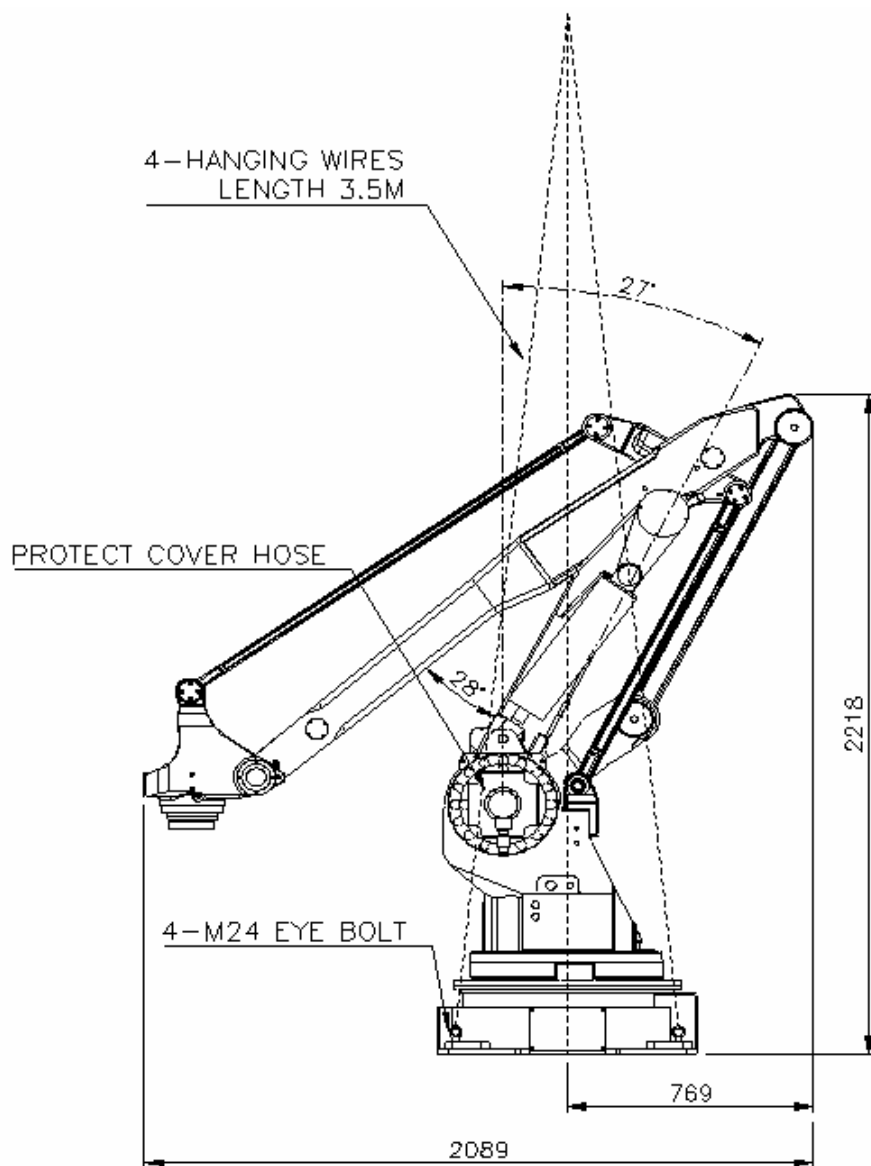

Fig 3.2 Transportation Method

### 3.3. How to Install



**NOTE:**

Before starting to unpack and install the robot, read the safety regulations and other instructions very carefully..



**Warning:**

The installation shall be made by qualified installation personnel and should conform to all national and local codes.

When unpacking the robot, check if it has been damaged during transporting or unpacking. In addition, strictly keep the following installation instructions because installation method and foundation are very important to maintain a good robot performance.

#### 3.3.1. Operating Conditions

- (1) Ambient temperature should range from 0°C to 45°C.
- (2) Ambient humidity should range from 20% to 85% RH, without dew condensation.
- (3) Less dust, oil, or moisture.
- (4) No flammable, corrosive liquid or GAS.
- (5) No impact and shacking.
- (6) No electrical noise generator near the robot.
- (7) If the robot is not immediately installed, keep it in a dry area at an ambient temperature between -15°C ~ and 40°C.

### 3.3.2. Installing the Robot Manipulator

The manipulator must be firmly fixed with eight M20 bolts. Note that all eight bolts must be used.

- Bolts : M20\*65 of higher(12.9) SOCKET HEAD BOLT
- Washer : OD = 44mm, ID = 25mm, T = 4mm
- Tightening Torque : 530±20Nm

The stiffness of the foundation must be designed to minimize the influence of the dynamic behavior of the robot.

In case of installing the robot on the floor, where the concrete thickness is more than 200mm, remove unevenness and cracks on the floor, and then fix the mounting plate with M20 Anchor Bolts. If the thickness of concrete is less than 200mm, the foundation work is required. Thus, inspect the foundation before robot installation.

※ Allowable load of bolts

The repeated tensile load per bolt: Approximately 8820 N ( 900 Kgf )

### 3.3.3. Dimension of Installation Surface

Fix the swivel base for robot's installation.

Refer to [Fig 3.4] for the dimension.

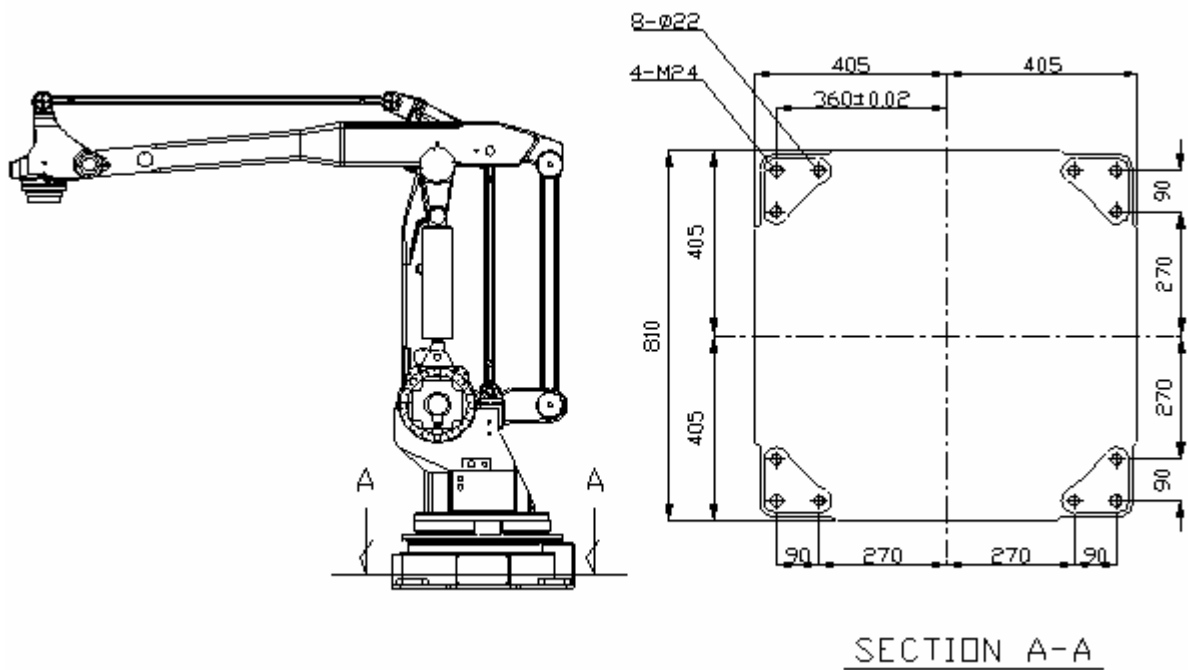

Fig 3.3 Dimension of Robot Installation

### 3.3.4. Accuracy of Installation Surface

The degree of flatness for the four attachment plate surfaces should satisfy the specification. Use a shim, if necessary. The rest of the surface must be flat within  $\pm 2\text{mm}$ .

#### ■ Cautions

- (1) The flatness of mounting plate must be within 1.0 mm.
- (2) The flatness of attachment plate surface for the 4 points must be within 1.0 mm ( $\pm 0.5$  mm).

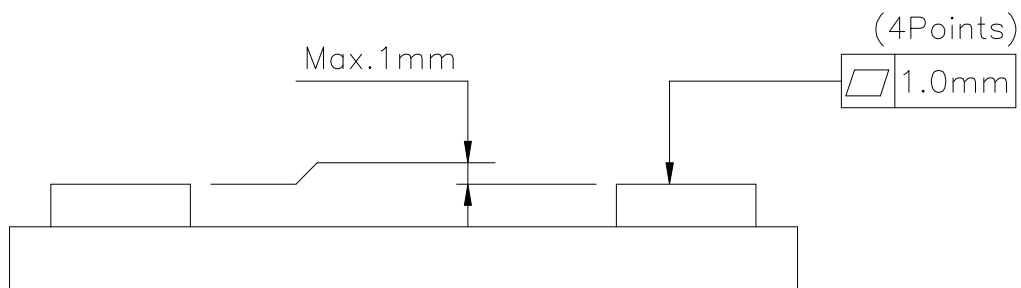

Fig 3.4 Accuracy of Installation surface

### 3.4. Allowable Load of Wrist Axis

The load, which will be applied to the mechanical interface of robot's wrist axis, is restricted by allowable weight, allowable load torque and allowable moment of inertia.

#### (1) Allowable Maximum Payload Weight :

Table 3-2 Allowable Payload weight

Robot Model		Allowable Payload Weight	Remark
TYPE	Servo Setting		
HR100P	60	Less than 60Kgf(600N)	
	100	Less than 100Kgf(1000N)	Standard
	120	Less than 120Kgf(1200N)	

- The servo set value is the set value according to the imposed weight to the robot, which is set according to the order condition when shipping the robot. The standard set value is 100, which is appropriately set to the imposed weight to the robot of 100kgf.

#### (2) Allowable Moment of Inertia :

Loads must be kept below maximum conditions shown in [Fig. 3.9~Fig 3.10].

[Fig 3.9] and [Fig 3.10] show the possible range in which a point load can be positioned, assuming the attached load is a particle. However, as the actual load(End Effector) is not a particle, calculate and evaluate the moment of inertia on each axis. The following exmple shows moment of inertia calculation assuming the attached load is a particle.

**(3) Load Inertia and Overhang length : [Refer to Fig. 3.9] :**

(※ Please refer to 3.5.4 for the method of calculating the load inertia.)

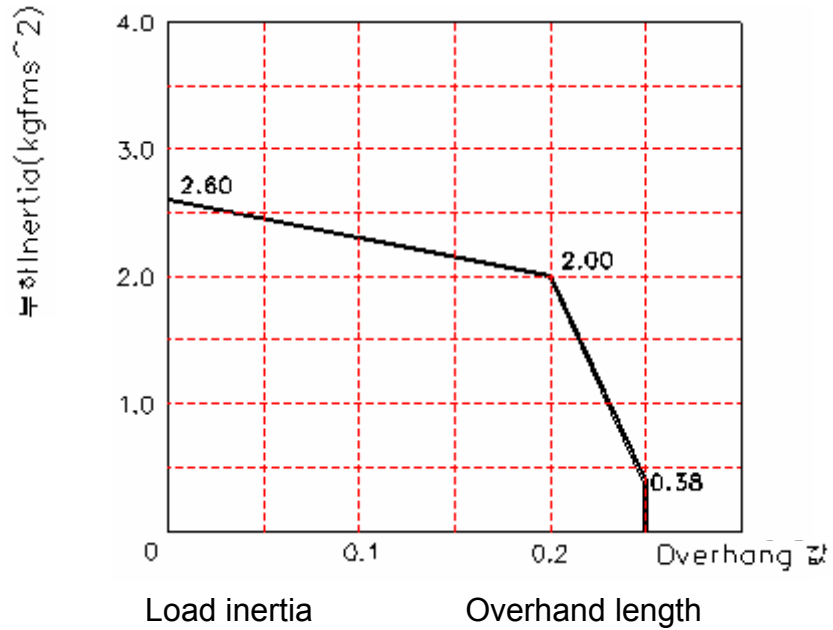

Fig 3.5 Permitted Load Diagram for Imposed Weight of 60kg

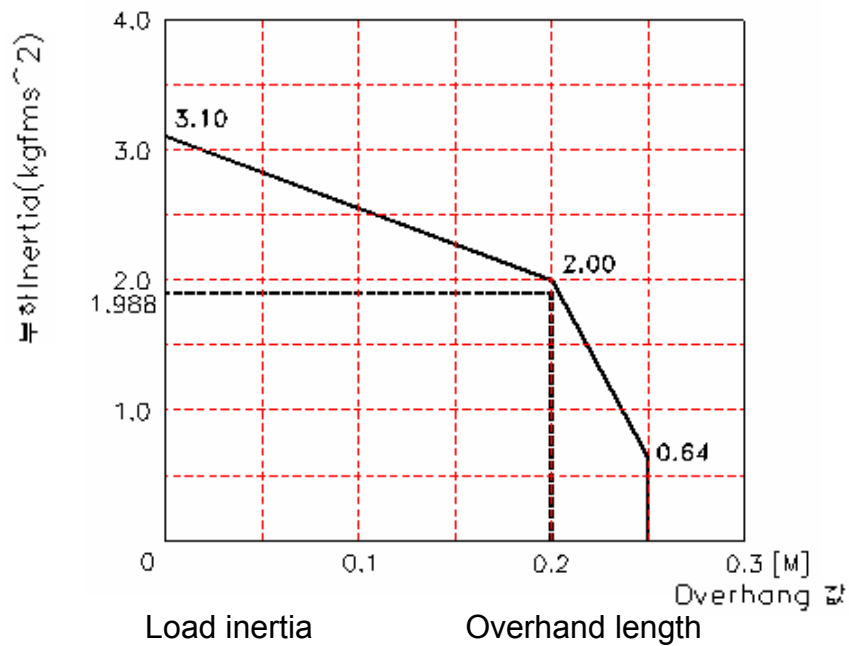

Fig 3.6 Permitted Load Diagram for Imposed Weight of 100kg

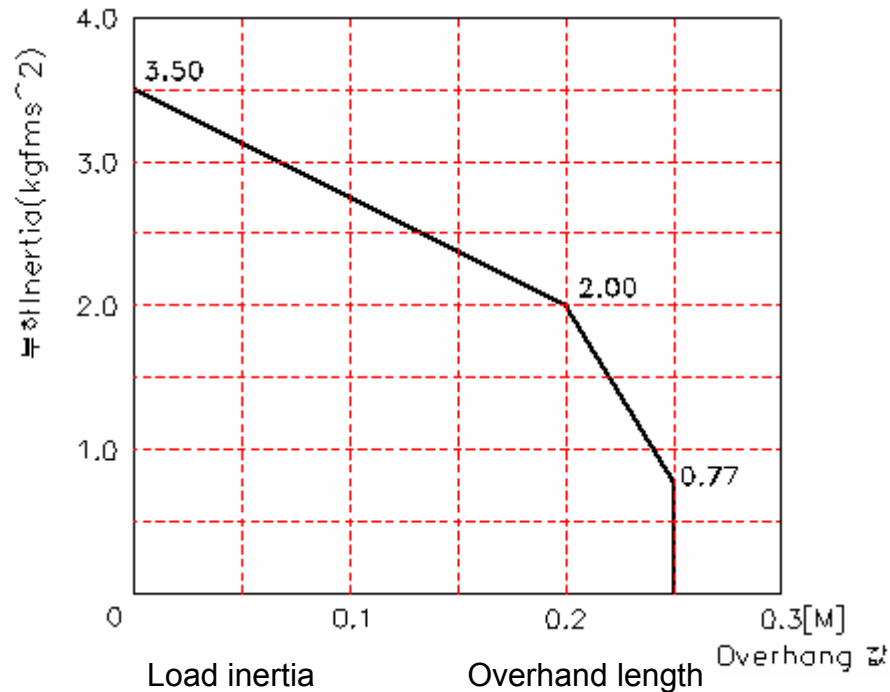

Fig 3.7 Permitted Load Diagram for Imposed Weight of 120kg

#### (4) Method of Calculating Load Inertia :

① What is load inertia?

It is the value estimated from the rotating center of the wrist axis of all inertia (mass inertia momentum) occurring between the hand and the work piece.

② Calculation example

[Load condition]

Mass of hand and work piece (M): 95 kg

Distance of gravitational center of hand and work piece. (l.c.g., Overhang=O.H.) : 0.2 m

Self inertia of hand and work piece (Jc.g.) : 1.60 kgfms<sup>2</sup>

[Load inertia (J)]

$$J = Jc.g. + M * lc.g.^2 / g \text{ [Acceleration of gravity]}$$

$$= 1.60 + 95 * 0.2^2 / 9.8$$

$$= 1.988 \text{ kgfms}^2$$

## ③ Permitted diagram satisfaction review

[Review] When applying HR100P-100, in Fig. 3-6

Weight of hand and work piece < Permitted weight :  $95 < 100 \Rightarrow$   
Satisfactory

Load inertia of hand and work piece < Permitted load inertia:  
 $1.988 < 2.00$  [In case of 0.2m overhang in Fig. 3-6]  $\Rightarrow$  Satisfactory

[Conclusion] Therefore it can be applied

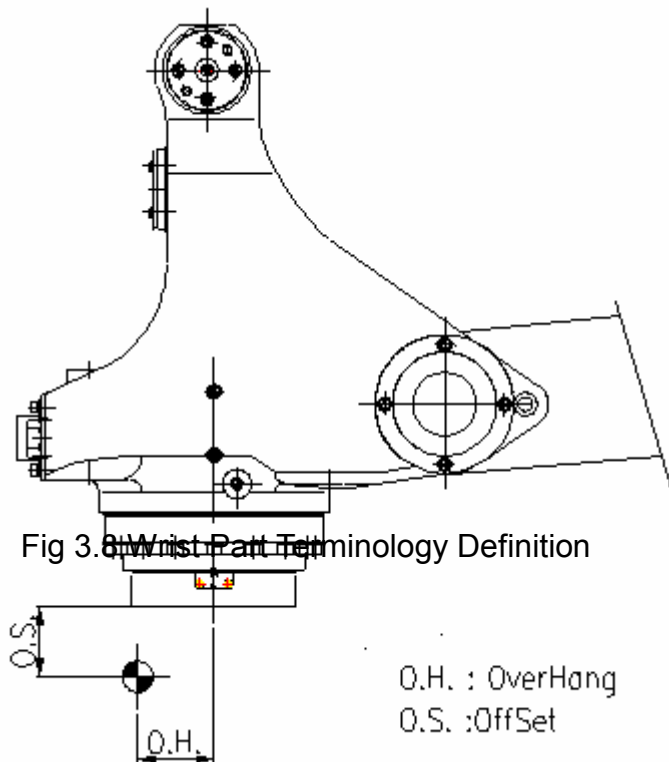



**4**

**Inspection**



## 4. Inspection

HR100P

This chapter provides the instructions for regular inspection and overhaul necessary for the prolonged lifetime of robot performance.

### 4.1. Inspection Item and Period

Inspection is positively necessary to continue and maintain the high performance of robot for long-term operation.

There are daily inspection and regular inspection. [Table 4.1-1] shows basic periods for regular inspections, so inspectors should make an inspection according to the indicated periods.

And overhaul every 35,000 operating hours.

The inspection periods have been reviewed for SPOT Welding. In case of high precision work such as handling, it is recommended to inspect at the half intervals of that period as shown in [Table 4-1].

Table 4-1 Inspection Schedule

Yearly Inspection				Yearly Inspection			
3 months	6 months	9 months	12 months	3 months	6 months	9 months	12 months
3 months	6 months	9 months	1 year	1 year & 3 months	1 year & 6 months	1 year & 9 months	2 years
Daily Inspection							

## 4.2. Inspection Item and Period

Table 4-2 Inspection Items and Periods

No.	Inspection Intervals			Inspection Items	Inspection method	Standards	Remark
	Daily	3 months	1 year				
Robot Manipulator and Axes common							
1	○			Cleaning	Examine dirt and dust with naked eyes		
2		○		Inspection wiring	Examine any cable damages Examine cable fixing bracket tightening bolts paint marking with naked eyes Examine any cable cover damages with naked eyes		
3		○		Main bolts	Examine paint marking with naked eyes		
4			○	Limit Switch/ Dog	Check the ON-OFF function of limit switch	Check if the emergency stop lamp is on when the limit switch is ON.	
5	○			Motor	Check the abnormal heating Check the abnormal sound		

No.	Inspection Intervals			Inspection Items	Inspection method	Standards	Remark
	Daily	3 mothns	1 year				
6			○	Brake	Check the ON/OFF operation of brake release switch (Note) Turn the switch off in a second because the ARM of working axis may be dropped when the brake release switch is on	When the brake release switch is OFF, ARM of End Effect will not be dropped.	
Axix S, H, V							
7	○			Reduction gear	Check the abnormal sound Check the shaking(vibrating)		
Axis R2, B, R1							
8		○		Reduction gear	Check the abnormal sound Check the vibrating		
9		○		End Effect tightening bolts	Examine paint marking with naked eyes		
10		○		Diversion	there is any diversion by rotating each axis to the right and reverse direction	should not feel diversion by touch	

### 4.3. Inspection of Main External Bolts

The recommended bolt torque is shown in [Fig 4.1] and [Fig 4.2].



Apply the appropriate torque, where required, using the torque wrench and place the paint marking where the check-up is completed

Table 4-3 Inspection part for main bolts

No	Inspection parts
1	H & V axis reduction gear case attachment
2	H & V axis motor attachment
3	V-Link attachment
4	R-BRK'T fixing bolt
5	T-axis motor attachment
6	End-effector attachment
7	V-arm attachment
8	T-link attachment

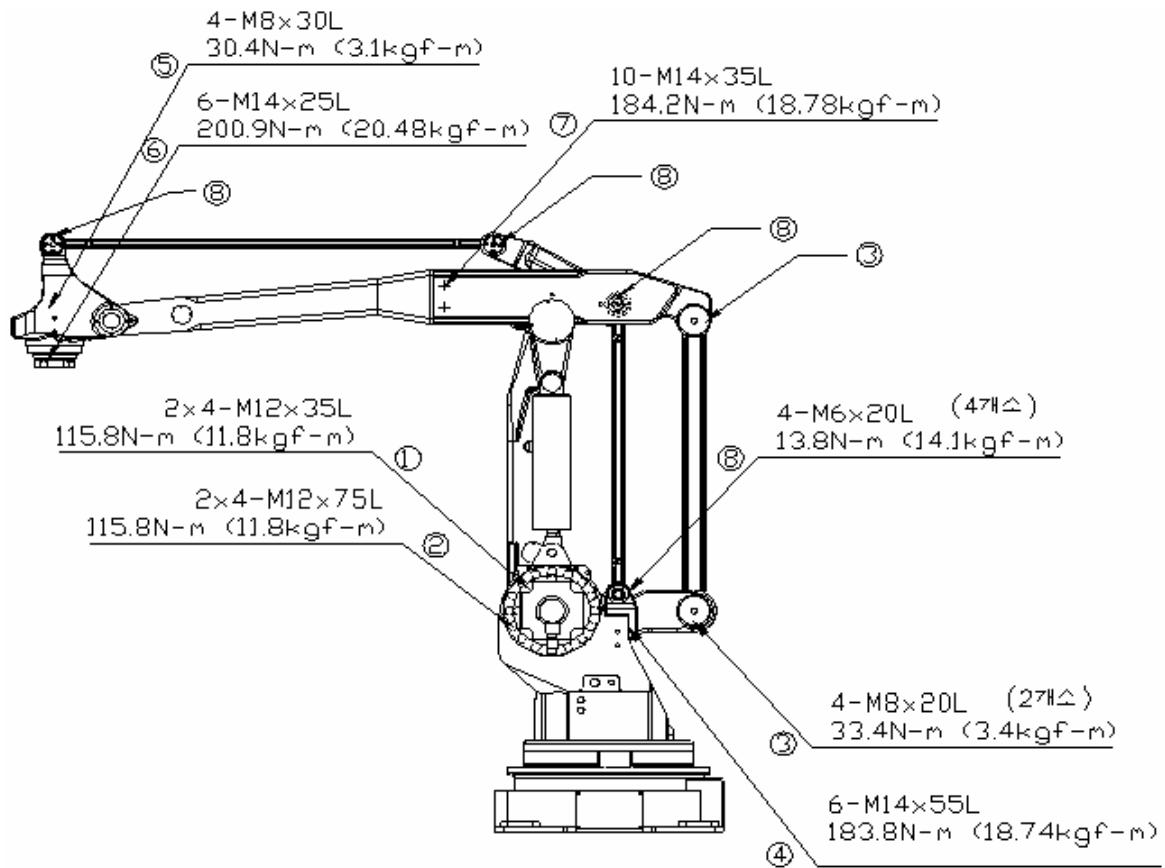

Fig 4.1 Inspection Part for Main Bolts

#### 4.4. Inspecting the Wrist Posture

If the posture of End Effector (hand device etc.), which is attached to the mechanical interface of wrist part, is abnormal due to the deformed ⑨T-LINK caused by the collision of hand, adjust it as follows.

- (1) Insert and fix the  $\phi 12$  polishing bar 350L(or 2×M12×80L) into the base HOLE of W-BODY between ⑦ and⑧.
- (2) ⑫Loosen the fixing bolt.
- (3) ②Insert the SHIM PLATE corresponding to the GAP between S-FRAME and ⑫S-BRK'T.
- (4) ⑫Fasten 184.2N-m (18.78kgf-m) with the fixing bolt for R-BRK'T, 6-M14×55L.
- (5) Remove the grinding rod/bar/sinker for lockup in the base hole or the bolt.

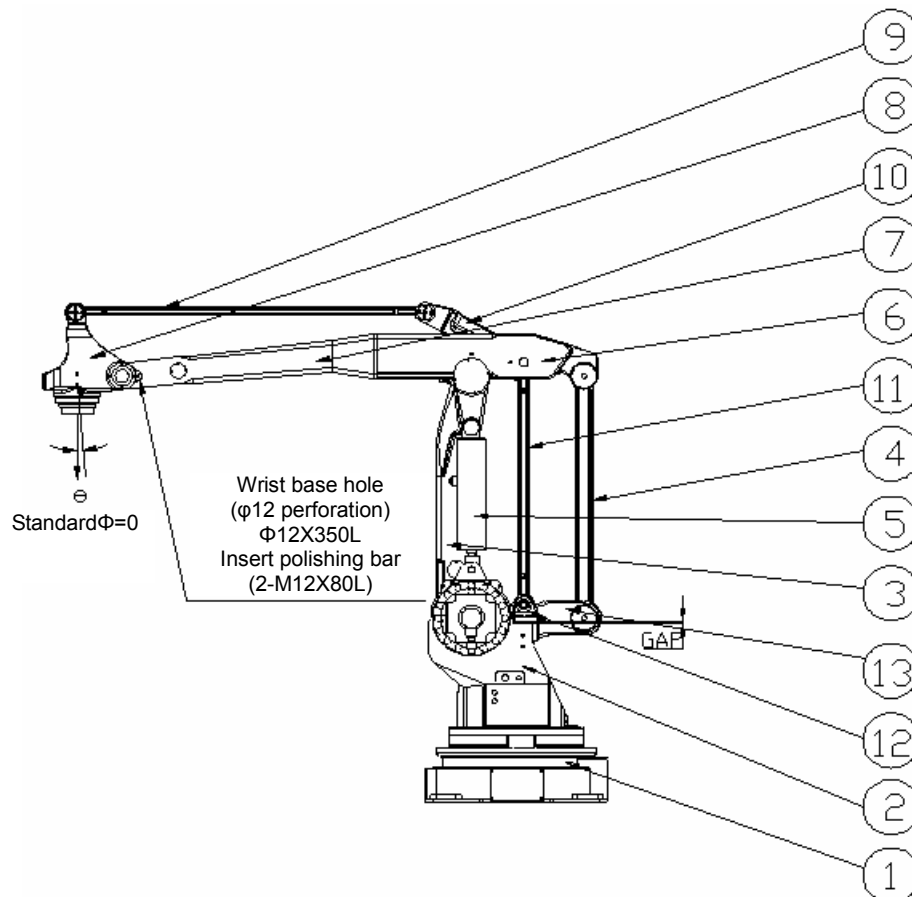

Fig 4.2 Posture Inspecting Direction

## **4.5. Inspection Internal Wiring**

Flexible cables are used for internal wiring of robot manipulator. However, when an internal cable is broken or crushed, the robot may malfunction. Therefore, regular inspection is required. When operating in the working envelope according to following inspection conditions, inspection must be completed in advance.

### **4.5.1. The Conditions of Safety Inspection**

When performing the operating work such as teaching (except shutting off driving source of industrial robot) in the working envelope, check the following articles before the work. If abnormality is found, correct the problem on the spot and then take necessary actions.

- Check if the covered wire and sheathing are damaged or not.
- Check if the manipulator can be operated or not.
- Check emergency stop function

### 4.5.2. Inspection Part

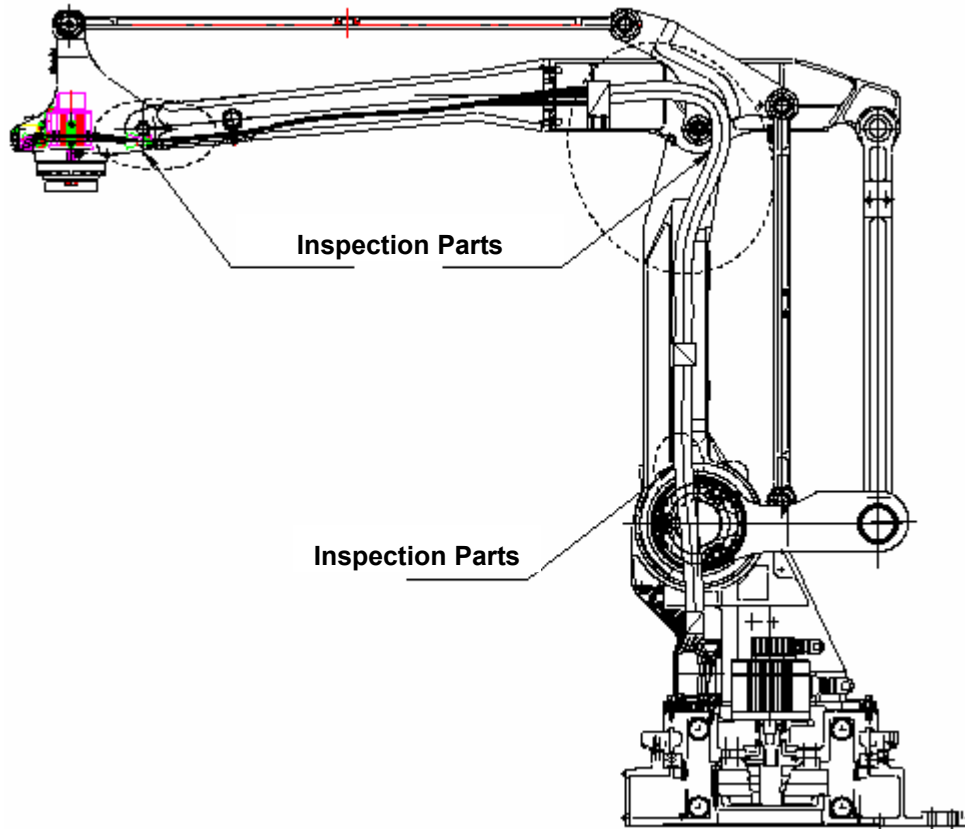
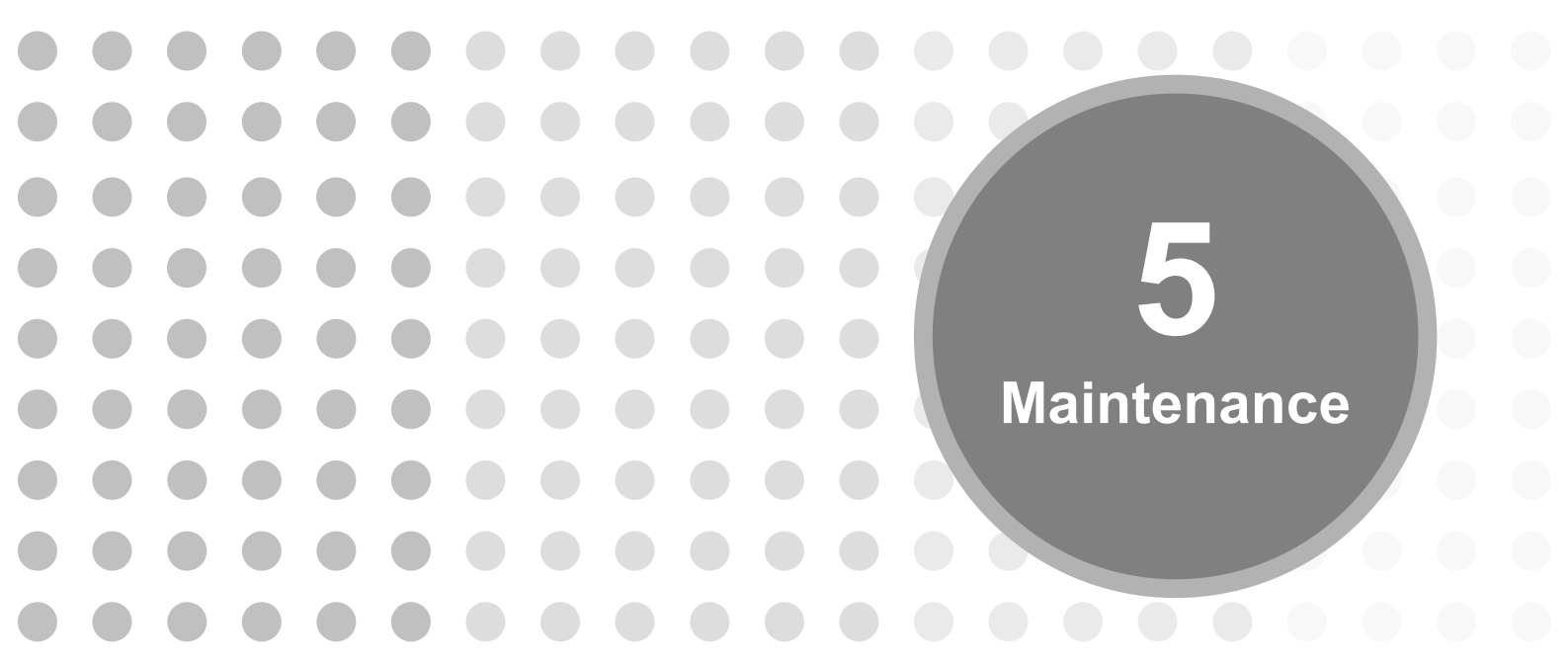

Fig 4.3 Cable Inspection Parts





**5**  
**Maintenance**



## 5. Maintenance

HR100P

### 5.1. Grease Replenishment/Replacement



#### **Attention**

If greasing is performed incorrectly, the internal pressure of the grease bath may suddenly increase, possibly causing damage to the seal, which would in turn lead to grease leakage and abnormal operation. When performing greasing, therefore, observe the following cautions.

- ① Before starting to grease, remove the plug from the grease outlet.
- ② Whenever possible, avoid using a compressed-air pump, powered by the factory air supply. If the use of a compressed-air pump is unavoidable, restrict the greasing pressure less than 7bar(7kgf/cm<sup>2</sup>)
- ③ Use grease only of the specified type. If not, may damage the reducer or lead to other problems.
- ④ After greasing, confirm that no grease is leaking from the grease outlet and that the grease bath is not pressurized, then re-attach the plug in the grease outlet.
- ⑤ To prevent accidents caused by slipping, completely remove any excess grease from the floor or robot.
- ⑥ When an ambient temperature is more than 40℃, be sure to shorten the period of replenishment in half.

#### ■ Periodic Replenishment / Replacement

##### **Lubrication Cycle**

- ✓ Grease Replenishment : 6,000 hours
- ✓ Grease Replacement : 12,000 hours

### 5.1.1. S-Axis Speed Reducer

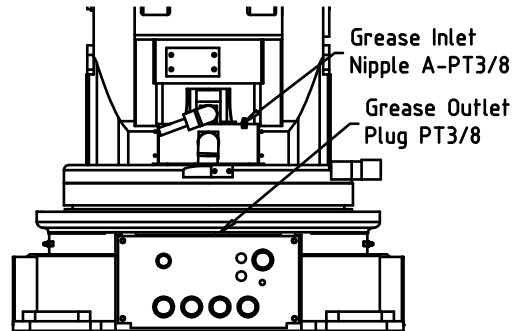

#### **Attention**

If grease is added without removing the outlet plug, the grease will go inside the motor and may damage it. It is absolutely necessary to remove the plug.

#### ■ Grease Replenishment

- ① Remove the grease outlet plug.
- ② Inject the grease into the grease inlet using a grease gun.

- ✓ Grease type : Molywhite RE00
- ✓ Amount of grease : 500cc

- ③ Attach the outlet plug with seal tape.

#### ■ Grease Replacement

- ① Remove the grease outlet plug.
- ② Inject the grease into the grease inlet using a grease gun.

- ✓ Grease type : Molywhite RE00
- ✓ Amount of grease : 3,650cc

- ③ The grease replacement is complete when new grease appears in the outlet port. The new grease can be distinguished from the old one by color.
- ④ Move the S-Axis for a few minutes to eject the old grease and then add grease until the new grease appears in the outlet port.
- ⑤ Wipe the outlet port with a cloth and attach the plug with seal tape.

### 5.1.2. H-Axis Speed Reducer

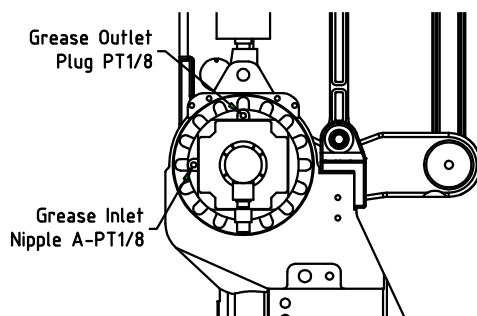

#### **Attention**

If grease is added without removing the outlet plug, it cause damage to the seal of reducer and grease will go inside the motor and may damage it. It is absolutely necessary to remove the plug.

#### ■ Grease Replenishment

- ① Make the H-Axis Arm vertical for ground.(H:90°-Floor Type, H:0°-Shelf Type)
- ② Remove the grease outlet plug.
- ③ Inject the grease into the grease inlet using a grease gun.

- ✓ Grease type : Molywhite RE00
- ✓ Amount of grease : 300cc

- ④ Wipe the outlet port with a cloth and attach the plug with seal tape.

## ■ Grease Replacement

- ① Make the H-Axis Arm vertical for ground.(H:90°-Floor Type, H:0°-Shelf Type)
- ② Remove the grease outlet plug.
- ③ Inject the grease into the grease inlet using a grease gun.

- ✓ Grease type : Molywhite RE00
- ✓ Amount of grease : 1,600cc

- ④ The grease replacement is complete when new grease appears in the outlet port. The new grease can be distinguished from the old one by color.
- ⑤ Move the H-Axis for a few minutes to eject the old grease and then add grease until the new grease appears in the outlet port.
- ⑥ Wipe the outlet port with a cloth and attach the plug with seal tape.

### 5.1.3. V-Axis Speed Reducer

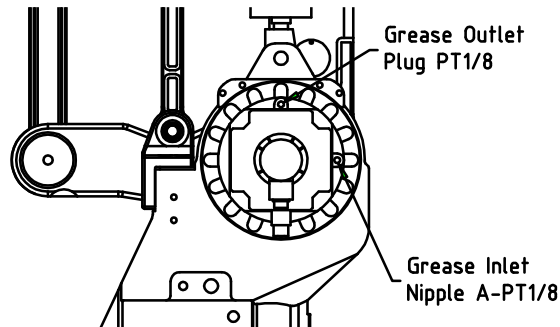

#### **Attention**

If grease is added without removing the outlet plug, it cause damage to the seal of reducer and grease will go inside the motor and may damage it. It is absolutely necessary to remove the plug.

#### ■ Grease Replenishment

- ① Make the V-Axis Arm horizontal for ground.(V:0°-Floor Type, V:-90°-Shelf Type )
- ② Remove the grease outlet plug.
- ③ Inject the grease into the grease inlet using a grease gun.

- ✓ Grease type : Molywhite RE00
- ✓ Amount of grease : 300cc

- ④ Wipe the outlet port with a cloth and attach the plug with seal tape.

## ■ Grease Replacement

- ① Make the V-Axis Arm horizontal for ground. (V:0°–Floor Type, V:-90°–Shelf Type )
- ② Remove the grease outlet plug.
- ③ Inject the grease into the grease inlet using a grease gun.

- ✓ Grease type : Molywhite RE00
- ✓ Amount of grease : 1,600cc

- ④ The grease replacement is complete when new grease appears in the outlet port. The new grease can be distinguished from the old one by color.
- ⑤ Move the V-Axis for a few minutes to eject the old grease and then add grease until the new grease appears in the outlet port.
- ⑥ Wipe the outlet port with a cloth and attach the plug with seal tape.

### 5.1.4. T-Axis Speed Reducer

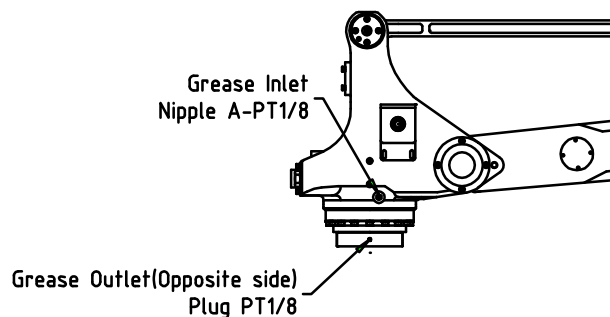

#### **Attention**

Do not inject excessive grease. The excessive grease would cause an abnormal operation.

#### ■ Grease Replenishment

- ① Remove the grease outlet plug.
- ② Inject the grease into the grease inlet using a grease gun.

- ✓ Grease type : Molywhite RE00
- ✓ Amount of grease : 200cc

- ③ Wipe the outlet port with a cloth and reinstall the plugs with seal tape

#### ■ Grease Replacement

- ① Remove the grease outlet plug.
- ② Inject the grease into the grease inlet using a grease gun.

- ✓ Grease type : Molywhite RE00
- ✓ Amount of grease : 435cc

- ③ The grease replacement is complete when new grease appears in the outlet port. The new grease can be distinguished from the old one by color.
- ④ Wipe the outlet port with a cloth and reinstall the plug with seal tape.

### 5.1.5. Bearing Joint Parts

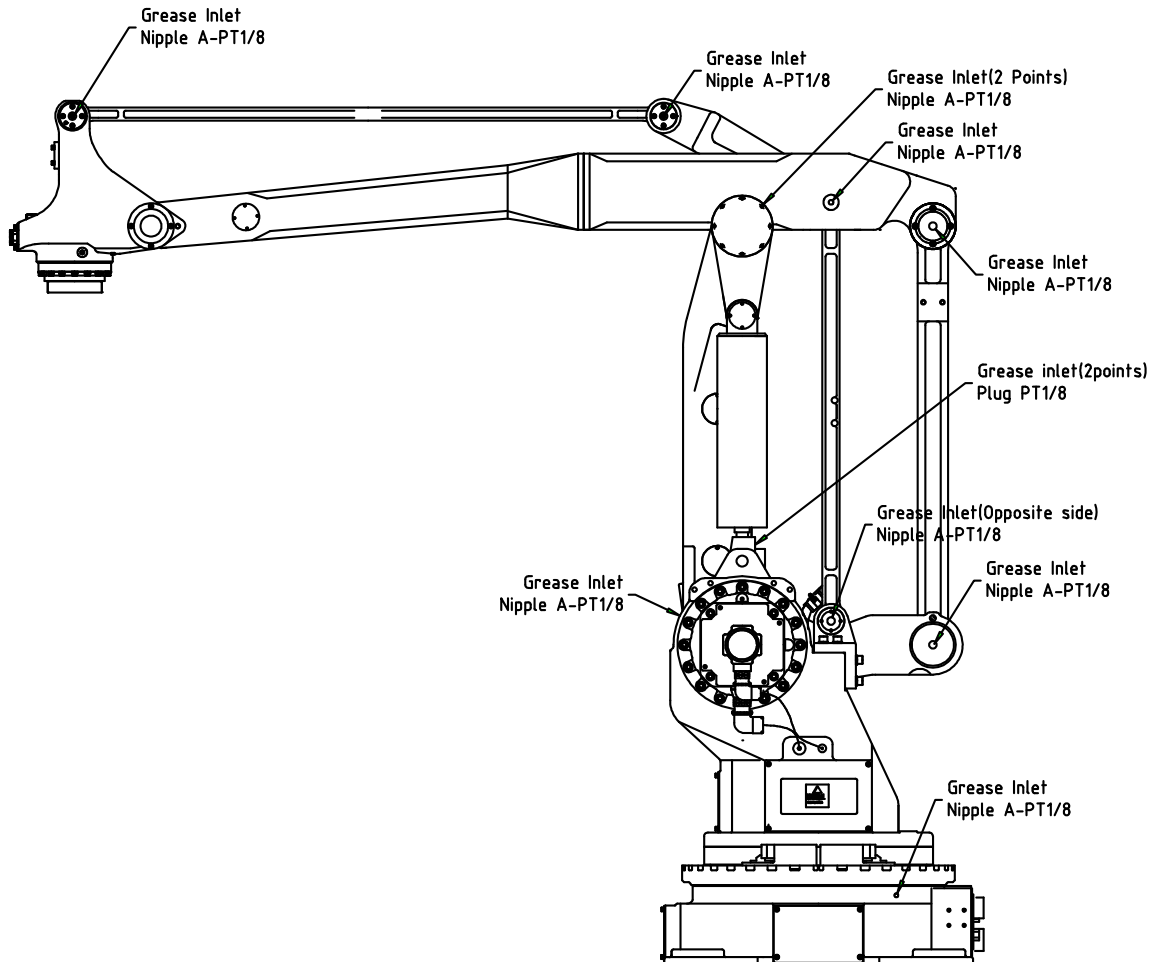

#### ■ Grease Replenishment

- ① Prepare a grease nipple A-PT1/8.
- ② As necessary, remove grease inlet plug and install grease nipple A-PT1/8.
- ③ Inject the grease into the grease inlet using a grease gun.

- ✓ Grease type : Alvania0769
- ✓ Amount of grease : 3cc

- ④ Remove grease nipple A-PT1/8 from grease inlet port.
- ⑤ Reinstall the grease plugs with seal tape.

## 5.2. Battery Replacement

The position data of each axis is preserved by the backup batteries. The batteries need to be replaced every two years. To replace batteries observe the following procedure.

- ① Keep the power on. Press the Emergency Stop button to prohibit the robot motion.



### **Attention**

Replacing the batteries with the power supply turned off causes all current position data to be lost. Therefore, zeroing will be required again.

- ② Dettach the battery bracket.
- ③ Take out the old batteries from the battery bracket.
- ④ Insert new batteries into it. Pay attention to the direction of batteries.

- ✓ Battery Spec. : ER6C(AA) 3.6V
- ✓ Manufacturer : Maxell

- ⑤ Reinstall the battery bracket.

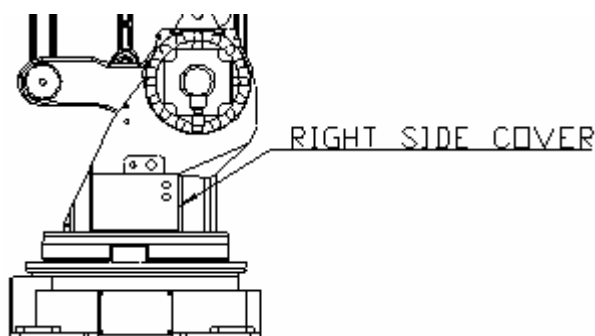



### **Attention**

- ✓ Do not dispose of the batteries. Dispose of the battery with industrial waste according to the laws and other rules in the country where the controller is installed.
- ✓ Do not recharge the batteries, otherwise batteries may result in exploding or overheating.
- ✓ Do not use any batteries other than the recommended one.
- ✓ Change the batteries only with the specified one.
- ✓ Do not short positive and negative terminals of battery.
- ✓ Do not expose batteries to high temperature or flame

### 5.2.1. Instructions for Battery Storage

- ① Do not keep the batteries at a high temperature and humidity. Keep it in the well-ventilating place without dew condensation.
- ② Keep it in a normal temperature, at relatively constant temperature( $20\pm 15^{\circ}\text{C}$ ) and at relative humidity of less than 70%.
- ③ Check the battery storage every six months, and manage them with first-in-first-out.

### 5.3. Internal Wiring

Replacement cycle of internal wiring depends on follows.

- Continuous operation
- Operating speed
- Atmosphere/environment

Inspect on a regular basis, every three months and check any damage on the cables or cable protect spring. If any damage, replace it.

Replace the cable every 16,000 operating hours regardless of working condition.



#### **Attention**

- ✓ As all the wires are flexible type, do not use any wires other than specified one.
- ✓ Wiring replacement must be done by unit.
- ✓ Do not use any Cable, protective spring, and Hose that have external damage as they may cause future problems.
- ✓ When purchasing robot cables, make inquiry of our service office about wiring type.
- ✓ Specify the length of wiring for connecting the robot with the controller.

### 5.3.1. Wiring Connection Diagram

Refer to [Fig 5.1] for part symbols of the internal wiring.

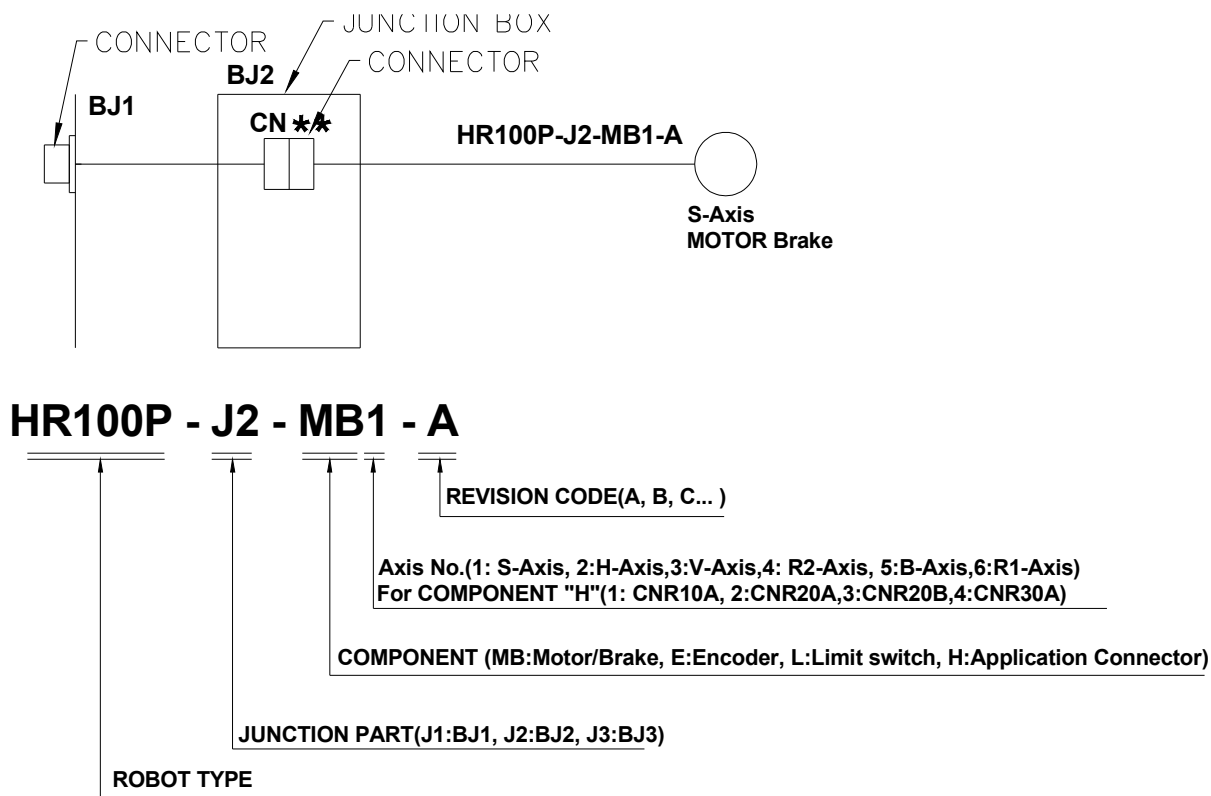

Fig 5.1 Explains of internal wiring

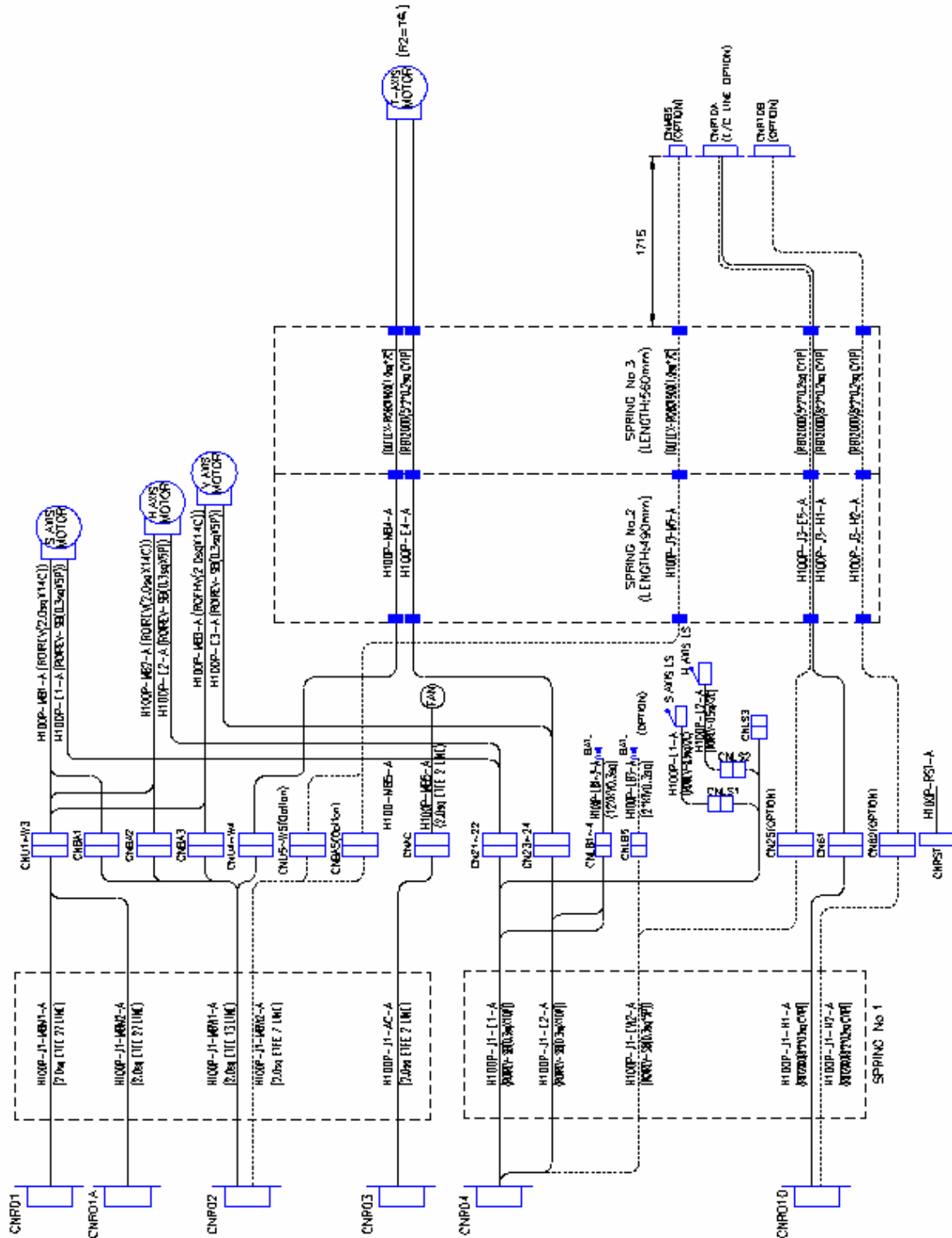

Fig 5.2 Wiring connection diagram





# 6

## Troubleshooting



## 6. Troubleshooting

HR100P

### 6.1. Troubleshooting Procedure

If a failure occurs during robot's operation, but it does not stem from the controller, it must be caused by damage on machine parts. The way to troubleshoot as quick and easy as possible should be to diagnose the problem. In addition, it is necessary to determine which parts cause the problem.

(1) Step 1 : Which axis occurs the problem?

First of all, check which axis causes the malfunction. In case that it is hard to detect the problem, check the following possible mechanical defaults.

- Is there any parts making noise?
- Is there any parts generating an overheating?
- Is there any parts have a play or backlash?

(2) Step 2 : Which parts have been damaged?

If the abnormal axes are determined, investigate which parts cause trouble. There could be many causes for one phenomenon. Refer to [Table 6-1] for the cause and phenomenon of the trouble.

(3) Step 3 : Dealing with malfunction parts

If the malfunction parts are confirmed, conduct relevant repair procedure based on the chapter 『6.3 Diagnostics and Resolutions for Major Parts Failure』. Contact our service office if you have any difficulties in dealing with problems.

## 6.2. Trouble Symptoms and Possible Causes

As shown in [table 6-1], there may be many parts as the cause of one phenomenon. Refer to next page to determine which part is malfunction.

Table 6-1 Trouble phenomenon and cause

Trouble phenomenon	Defect parts					
	Reduction gear	Brake	Motor	Encoder	Fulcrum bearing	
Overload [Note1]	○	○	○		○	
Displacement	○		○	○		
Abnormal sound occurrence	○	○	○		○	
Noise in operation [Note 2]			○		○	
Staggering at stop [Note 3]			○	○	○	
Irregular twitching [Note 4]			○	○	○	
Abnormal deviation			○	○		
Free fall of an axis	○	○				
Overheating	○	○	○	○		
Incorrect action and out of control movement			○	○		

[Note 1] Overload ----- Phenomenon occurring when a load exceeds the rated motor load. In specific, thermal relay of circuit protector is tripped.

[Note 2] Noise in operation -- Phenomenon which occurs vibration on operation.

[Note 3] Staggering at stop - Phenomenon which gives oscillating motion when the robot stops.

[Note 4] Irregular twitching --- Phenomenon which gives sporadic twitching when the robot is not in motion.

## 6.3. Diagnostics and Resolutions for Major Parts Failure

### 6.3.1. Fulcrum Bearings

Vibration, abnormal sound and overloads are observed when a fulcrum bearing is damaged. When the Nut holding bearings becomes loose, bearing play occurs. It may damage the bearings.

#### ■ Diagnostics

- ① Shake the 1<sup>st</sup> ARM and 2<sup>nd</sup> ARM back and forth to check if bearing exhibits any play. (In case of using a chain block, check the bearings for the play, with the 1<sup>st</sup> ARM and 2<sup>nd</sup> ARM posture maintaining and without any overload to the reduction gear.
- ② Check to see if the robot touched other peripheral equipment before the malfunction.

#### ■ Resolution

- ① Replace the bearing. A Chain Block is needed to lift and hang the robot ARM. Contact our service office for any difficulties..

### 6.3.2. Reduction Gear

Vibration and abnormal sound will be occurred when a reduction gear is damaged. In this case, it causes overload and abnormal deviation disturbing normal operation. Sometimes overheating may result. The robot may also become completely immovable, or a position offset error may occur.

#### [Main Axes (S, H, V)]



When turning [ON][OFF] the brake release switch of axis H and axis V, be sure to take necessary precautions to prevent the ARM from dropping, and then switch the brake release [ON][OFF].

#### ■ Diagnostics

- ① Check out any vibration, abnormal sound or overheating of the reduction gear when the robot is in operation.
- ② Check out any play and abrasion in the reduction gear. And check if any abnormality is felt by hand when shaking 1st ARM back and forth with the brake release switch of axis S [ON].
- ③ Check if peripheral equipment has been contacted with the robot before the abnormality.  
(Damage may occur to the reduction gear due to the contacting impact.)

#### ■ Resolution

- ① Replace the reduction gear. A chain block is needed to lift and hang the robot ARM. Contact our service office for any difficulties.

#### [Wrist Axes (R2=T)]



When turning [ON][OFF] the brake release switch, be sure to take necessary precautions to prevent the ARM from dropping, and then switch the brake release [ON][OFF].

#### ■ Diagnostics

- ① Check out any vibration, abnormal sound, or overheating of the reduction gear when the robot is in operation.
- ② Check out any play in the reduction gear by shaking the End Effector (such as spot gun and hand devices, etc.) back and forth.
- ③ Turn motors off , with the brake release switch [ON], and check that the axis can be rotated by hand. If not, the reduction gear is in bad condition.
- ④ Check if peripheral equipment has been contacted with the robot before the abnormality.  
(Damage may occur to the reduction gear due to the contacting impact )

**■ Resolution**

① Replace the reduction gear.

② Replace the entire wrist section.

(The replacement of entire wrist should be a quick and reliable resolution as it takes time and necessary equipment for reduction gear replacement)

### 6.3.3. Brakes

In case of brakes failure, each axis possibly drops with the motors [OFF]. Or, in reverse, brakes possibly operate even with the motors [ON]. The latter causes overload and noise.



When intending to operate the entire robot without the motors [ON], operate it with the brake release switch [ON]. Before turning the switch [ON], take necessary precautions to prevent the ARM from dropping as the robot ARM will drop by gravity.

#### ■ **Diagnostics**

- ① Check if the brake can be heard in operation, by turning the brake release switch [ON] [OFF] alternately with the motors[OFF]. If not heard, the vrake cable may be broken. (When operating the brake release switch [ON][OFF], be careful of ARM dropping. The brake release switch is located on the panel in the controller cabinet door.)

#### ■ **Resolution**

- ① If cables turn out to be good condition, replace the motor.

### 6.3.4. Motor

Motor failure causes abnormal operation of robot such as staggering at stop, irregular twitching and noise in operation. Besides, It may cause overheating and abnormal sound.

Check the reduction gear and fulcrum bearing as well in order to determine which part causes the abnormality. It is because that similar phenomenon is observed when the reduction gear is damaged.

- **Diagnostics**

- ① Check for overheating and abnormal sound. .

- **Resolution**

- ① Replace the motor.

### 6.3.5. Encoder

Position offset, malfunction, and out of control movement as well as staggering at stop, irregular twitching may occur when the Encoder is in bad condition. This case has nothing to do with such phenomena as mechanical abnormal sound, overheating, and vibration

#### ■ Diagnostics

- ① Check for any encoder data failure.
- ② Use reference pins and blocks to check the positional data is correct at pin position.
- ③ Check for any irregular variations in the encoder data when moving each robot axis.
- ④ Replace the servo amp board, BD440 to check errors.

#### ■ Resolution

- ① If cabling turns out to be in good condition without any damage, replace the encoder.
- ② If there is no error after replacing the servo amp board BD440, replace the servo amp board.

## 6.4. Encoder Zero Setting

It is necessary to reset the origin when encoder data has been corrupted due to some problems and when the motor is replaced.

Level and Block is adopted as the position setting method for each axis. The origin must be set in order of axis 4, 5, and 6 considering axis interference of the wrist due to its structural characteristic.



### Warning

In this work, there is a part performing in the state of motor [ON]. Therefore, this work must be performed in pairs. One must always be ready to activate an emergency stop. The other must perform the work quickly but carefully. An escape route should be determined before starting work.

### Necessary tools and parts

Table 6-2 Necessary tools and parts

Axis name Necessary tools	S	H	V	R2
Location alignment pin	-	○	○	-
Location alignment scale	○	-	-	○

### 6.4.1. Zero Setting

- (1) Zero Setting for the basic posture  
Set the control device in a teaching mode, and turn the motor 「ON」.  
Move the axis to the basic posture, and push the pin for zero setting in, making reference to the Fig 6-1.  
If it is impossible to follow the above instruction, set the zero setting by using the brake release switch.
- (2) Encoder Reset  
『Refer to 6-4-3 Encoder Reset 』
- (3) Compensating the Encoder Data Software  
Input the deviation value of Encoder to the software memory.  
Refer to the instruction manual for compensating the encoder zero setting.

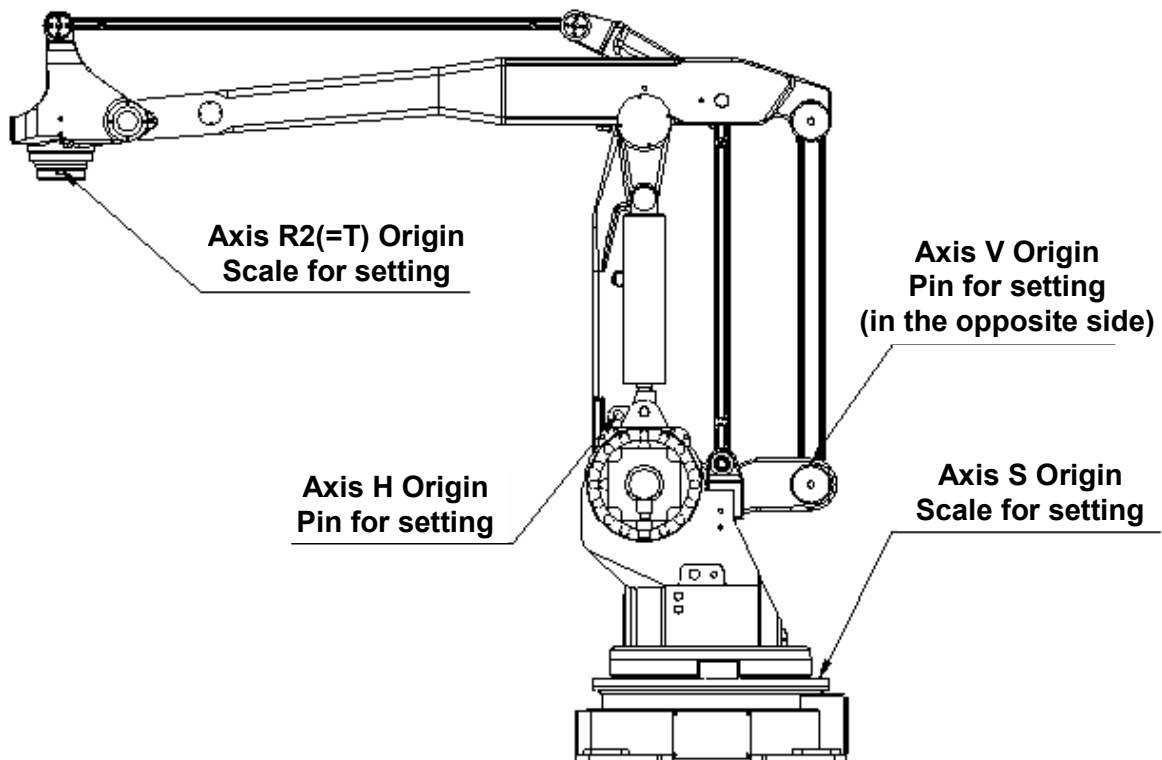

Fig 6.1 Location of pin hole for zero setting in axis

## 6.4.2. Zero Setting for Wrist Axis

- (1) Zero Setting for the basic posture
  - Set the control device in a teaching mode, and turn the motor「ON」.
  - If the motor cannot be 「ON」 due to a failure, set the basic position of robot by pushing the hand which is attached to the Axis T.
  - Set the center of notchmark in the side of SCALE to the 'V'- notch of decelerator part.
- (2) Encoder Reset.
- (3) Compensating the software of encoder value

### 6.4.3. Encoder Reset

- ① Turn the controller power [ON] for 3 minutes, and then turn it [OFF].
- ② Take off the rear cover of the robot. (Check the batteries/encoder backup batteries are well connected.)
- ③ Turn the controller power [ON].
- ④ After connecting the reset connector(CNRST1 ~ 6) of the axis to reset with the plug located in the cover of the rear robot for 5 seconds, pull the reset plug out. (Reset connectors of the respective axis should be connected for the reset work only. Besides, there is usually no connection in the reset connector.
- ⑤ Cover the rear of the robot.

#### 6.4.4. Confirming the Reset



##### Warning

This operation is used to verify an encoder reset was performed correctly. Note this procedure is different from 『Encoder Calibration』 which determines encoder data from basic posture of the robot.

The number of pulses per revolution of the currently used encoder data is 8192bit irrespective of the robot model. The current value of encoder displays what is added by compensation value to the actual encoder value. In other word, the difference between the current value of encoder and the absolute compensation value of encoder is real encoder value.

After reset, the actual encoder value is classified as what it becomes less than 1 revolution and as what it becomes less than minus 1 revolution depending on the robot model. Follow the procedure below to confirm the encoder has been successfully reset.

- ① Connect the encoder connectors of motors and turn controller power on. Select 『Encoder Calibration』 in a constant setting mode, and select 『Encoder Calibration (Input Value)』 at the next display. The encoder calibration value for each axis is displayed in left-side and the present encoder value in right-side.
- ② Move the cursor to the encoder calibration value of axis that were reset, and press 『0』 .
- ③ Confirm that the present encoder value is within the range of 0~8192. If not, reset the encoder again.



##### Warning

After connecting the motor, the following errors may occur according to the discharge of electricity of the encoder internal capacitor.

- E0107 Encoder error: Poor bit sequence
- W1014 : Voltage drop of encoder battery.

In this case, turn controller power on for more than 10 minutes, and reset encoder. And then, turn controller power 『OFF』 once again, and power 『ON』 . It will be restored to normal condition.

### 6.4.5. Encoder Calibration(Data input) and Selection

- It is necessary to compensate encoder data for the basic position of each axis.
- Refer to 『Encoder calibration』 in the Controller Manual for details.
- Select 『Encoder calibration (Position Rec)』 in the mode of Constant.

#### [Encoder Calibration Screen]

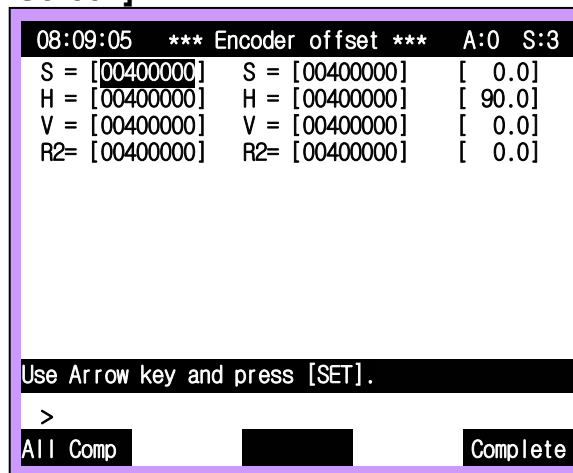

- (1) Press [SET] key after moving the revolving bar into the desired location to set by using [↓][↑] keys, and the following message is displayed.

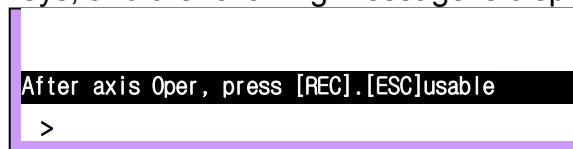

- (2) Move the robot to the position that the origin pin becomes [ON] with axis operating button, and press [REC] key.
- (3) Press 『[PF5]: Complete』 to complete setting.



#### Warning

In case of encoder DATA compensation after replacing motor, check if the motor power is on with the power 『ON』 .





**7**

**Recommended  
Spare Parts**



## 7. Recommended Spare Parts

HR100P

The recommended spare parts for robot are as follows. Please check robot serial number and manufacturing date when purchasing, and contact our service office.

[Category]

A : Regular maintenance parts(what is replaced regularly)

B : Essential spare parts (what is of high frequency)

C : Essential component parts

D: Machine parts

Table 7-1 Spare Parts List

Category	Name	Manufacturer	Per set		Application
	Specification	Model number	Use	Rec.	
A	Grease	Parkerizing (Japan)		16Kg/ CAN	S, H, V, R2, B, R1 axis decelerator part
	Long Time PD0				
A	Grease	Parkerizing (Japan)		16Kg/ CAN	Gears and bearings of each axis
	Long Time PD2				
A	Encoder battery	HHI	3 EA	3 EA	Exchange every 2 years irrelevant from the moving time
	H120-LB*-A(*=1,2,3)				
B	AC servo motor	HHI	3 EA	1 EA	Common for S, H, V axis
		RM-0164-007-A2/S1			
B	AC servo motor	HHI	1 EA	1 EA	R2 axis
		100-POW210-0.0			
B	Encode	HHI	3 EA	1 EA	Common for S, H, V axis (Consult with HHI Service Dept.)
		RM-0164-07E-A2/S1			
C	RV decelerator	HHI	1 EA	1 EA	S1 axis
		RM-0164-101-S1			

## 7. Recommended Spare Parts

Category	Name	Manufacturer	Per set		Application
	Specification	Model number	Use	Rec.	
C	RV decelerator	HHI	2 EA	1 EA	Common for H and V axis
		RM-0164-008-A2			
C	RV decelerator	HHI	1 EA	1 EA	R2 axis
		100-P0W220-0.0			
C	TOP-LINK	HHI	1 EA	1 EA	Upper position link
		100-P0V060-0.0			
B	T axis wiring assembly	HHI	1SET	1 SET	Wiring and air tube between the left/right side of the robot and the T axis motor
		H100P-MB4-A(1EA) H100P-E4-A(1EA) H100P-J3H1-A(1EA) 100-P0E170-0.0(1EA)			





# 8

## Internal Wiring Diagram



Internal wiring is shown in a connection diagram per unit, and thus utilize it to inspect and replace the wiring.

### 8.1. Manipulator Configuration

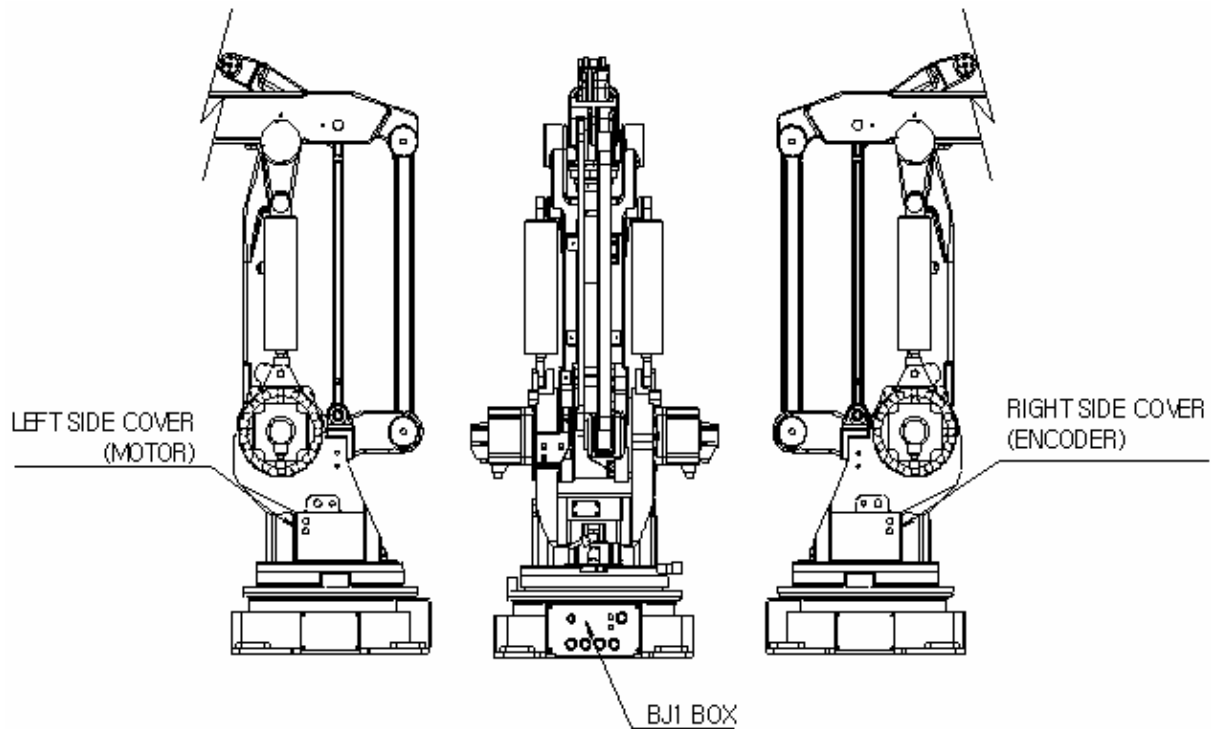

Fig 8.1 Manipulator Configuration

8.2. Wiring Diagram

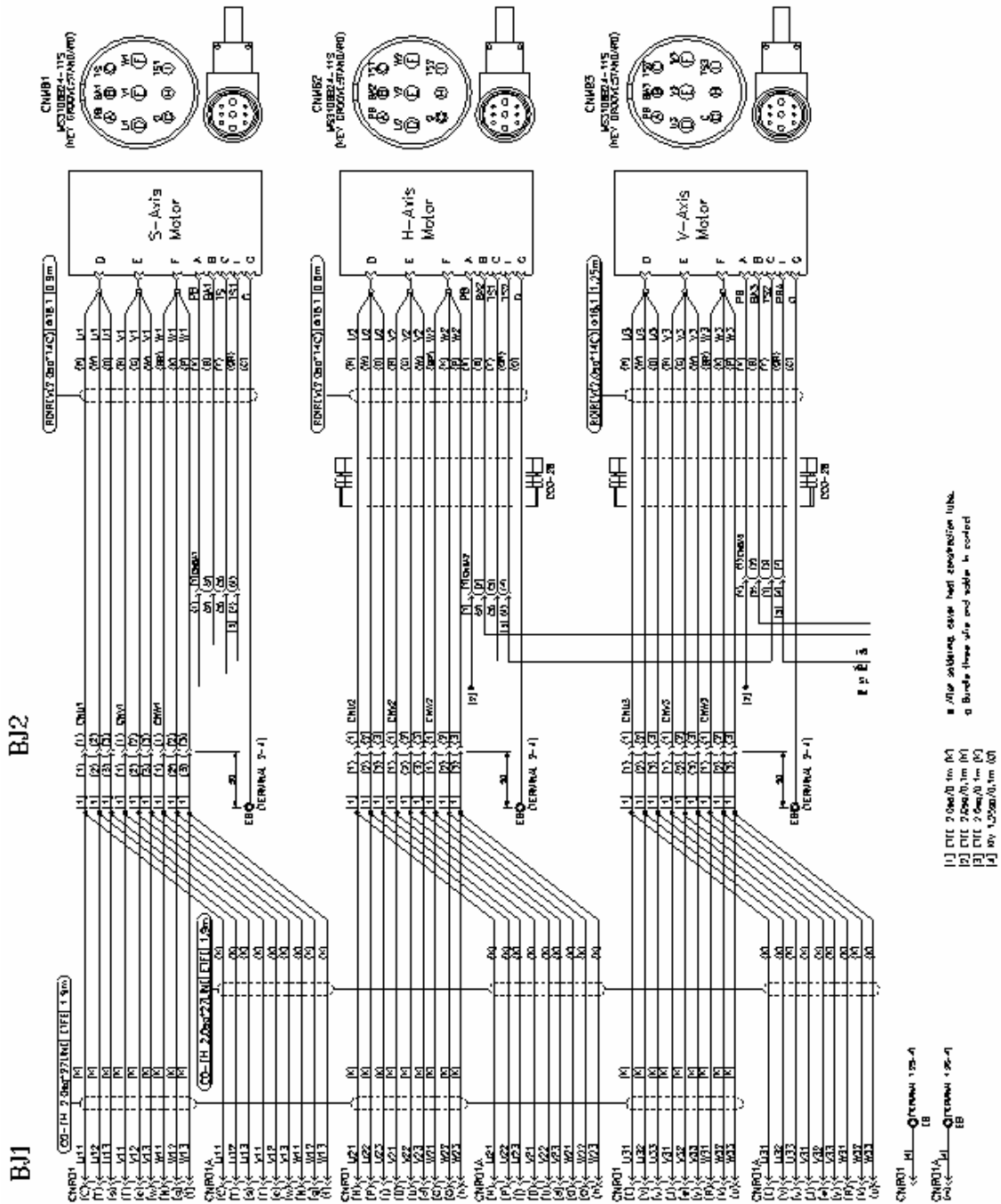

Fig 8.2 Wiring connection diagram

\*Option: This diagram only applies when the 5<sup>th</sup> axis is used as an additional axis. You need a separate diagram

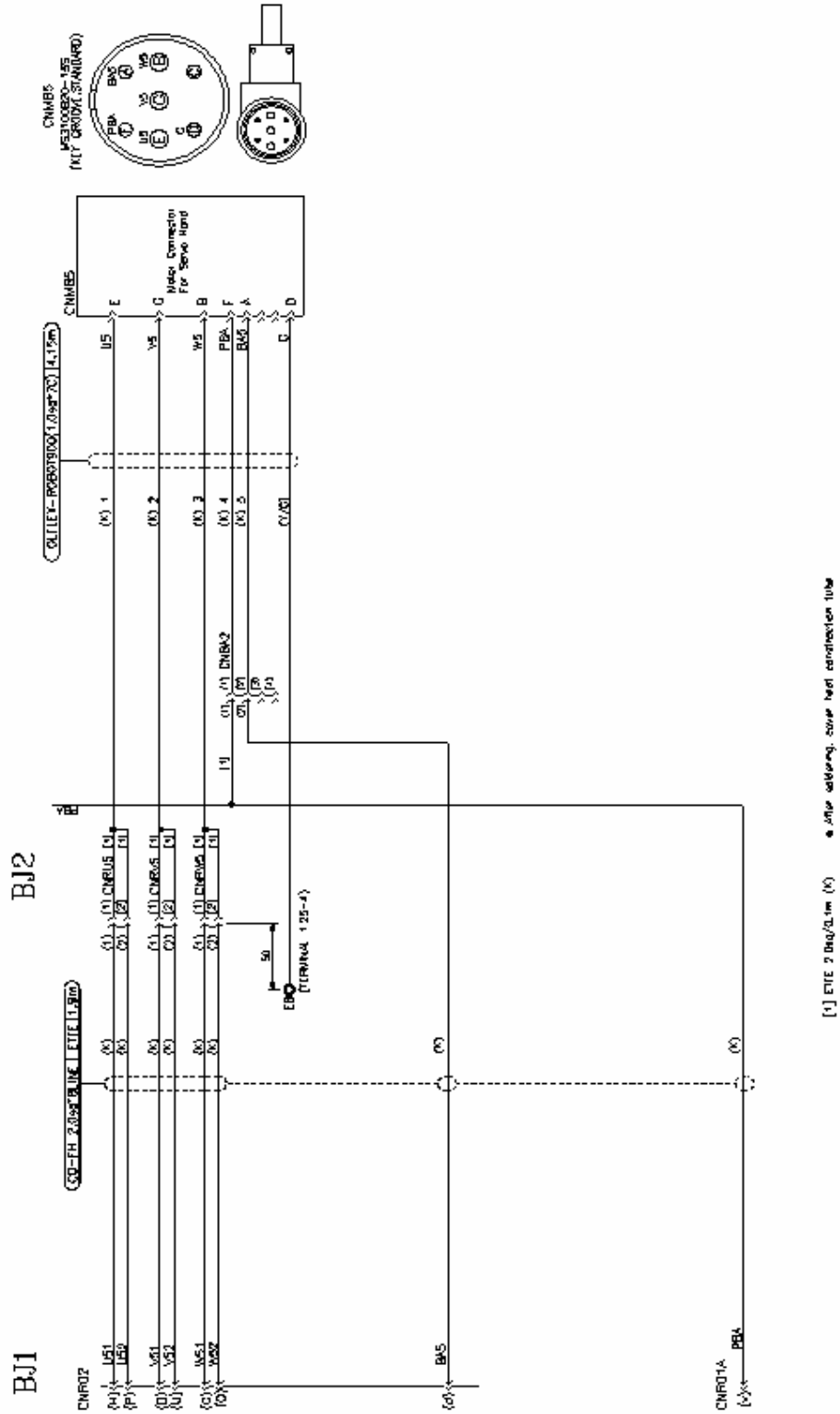
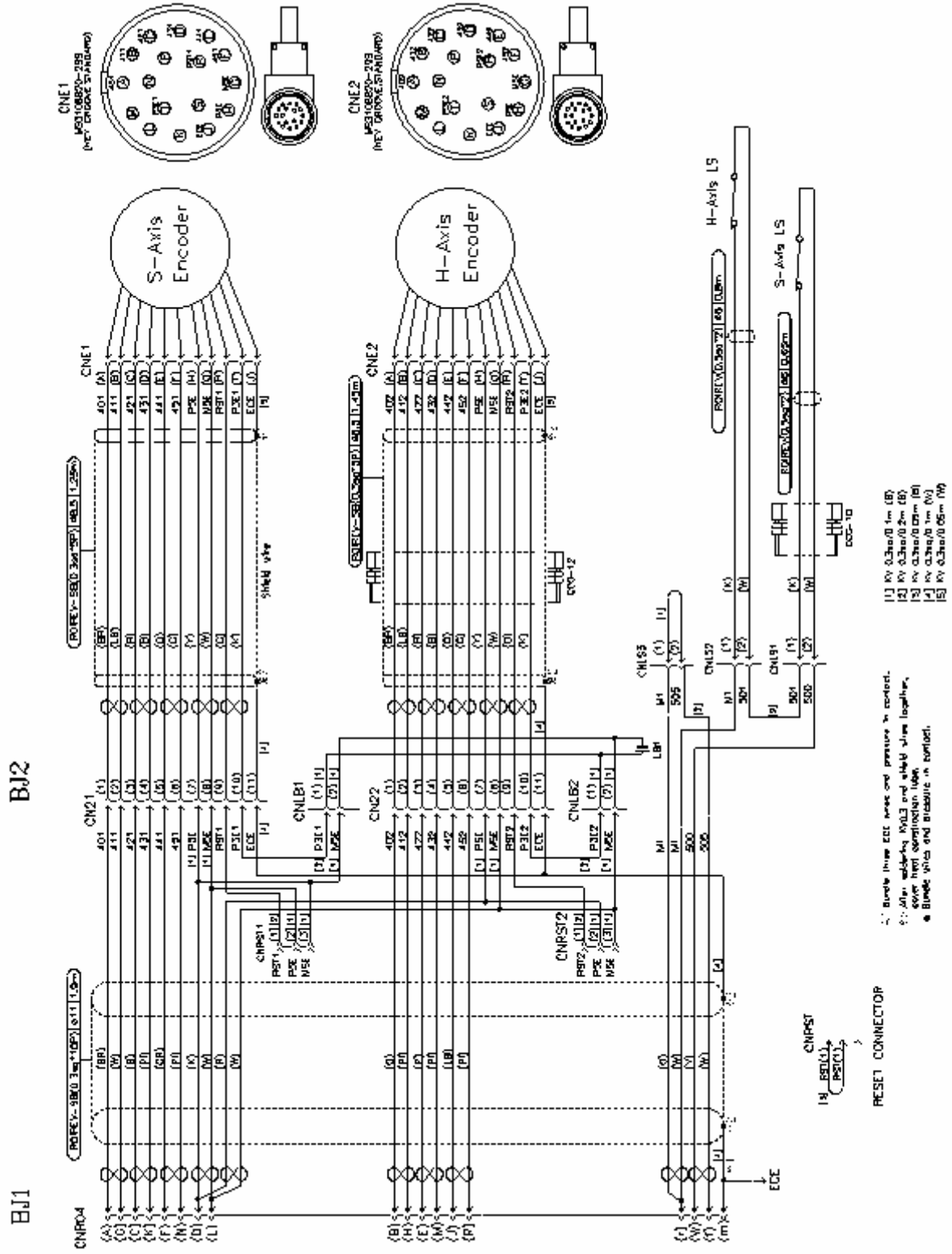

Fig 8.3 Servo hand wiring Connection (Optional)

## 8. Internal Wiring Diagram



- [1] Ky 0.3mm/0.1mm (B)
- [2] Ky 0.3mm/0.2mm (B)
- [3] Ky 0.3mm/0.3mm (B)
- [4] Ky 0.3mm/0.1mm (N)
- [5] Ky 0.3mm/0.05mm (N)

- ① Bundle three EDC wires and pressure in contact.
- ② After soldering, Axils and shield wire together, cover heat contraction tube.
- ③ Bundle wires and measure in contact.

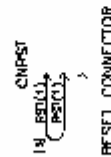

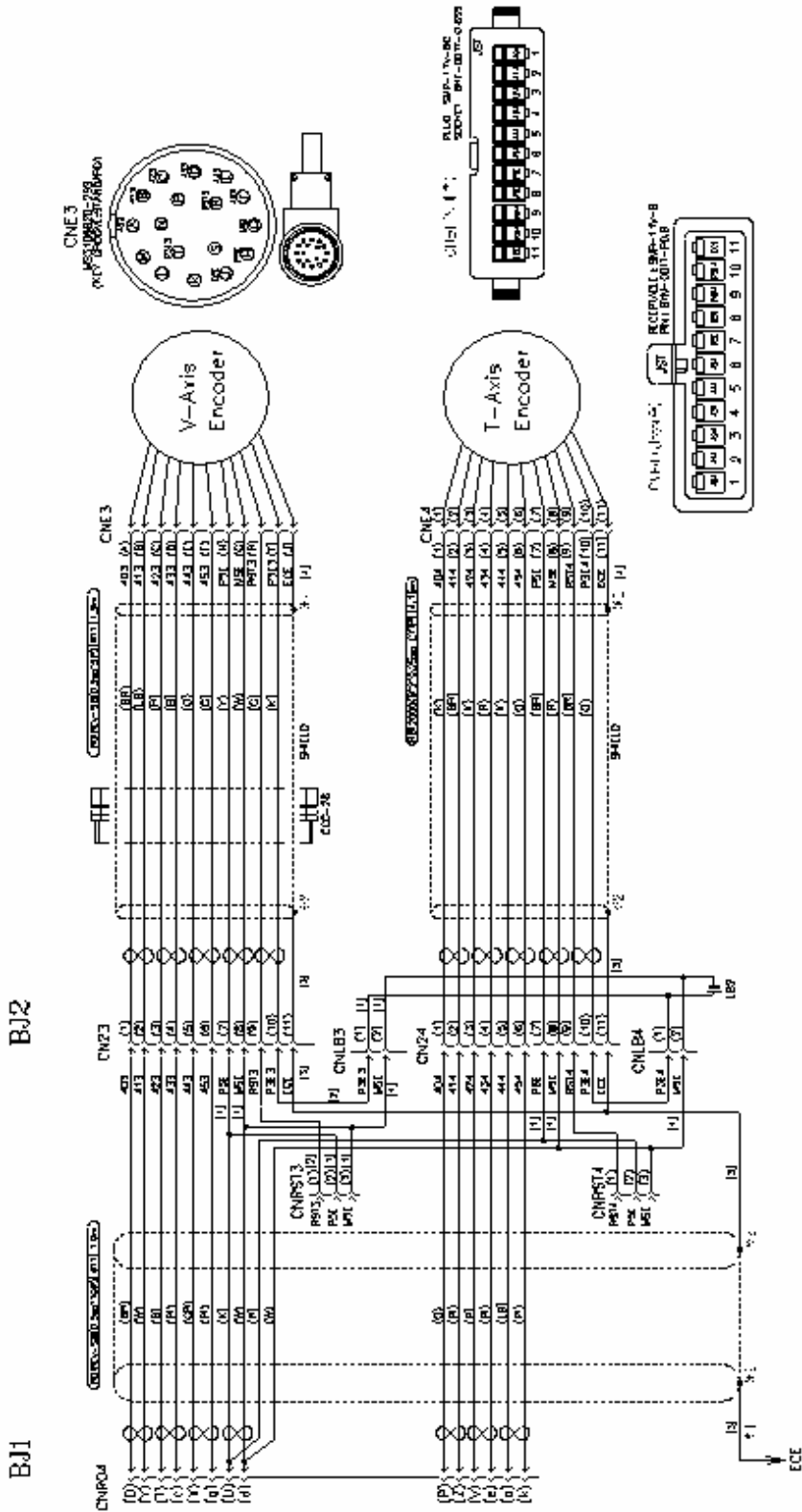

Fig 8.5 Encoder Wiring Connection No.2

- [1] RV 0.3m/0.1m (B)
- [2] RV 0.3m/0.2m (B)
- [3] RV 0.3m/0.1m (B)
- [4] RV 0.3m/0.09m (V)

- [5] Brake lines ECC wire and pressure is correct.
- [6] After soldering CNL3 and CNL4 wire together, stop high speed construction tube, a Brake wire and pressure is correct.

## 8. Internal Wiring Diagram

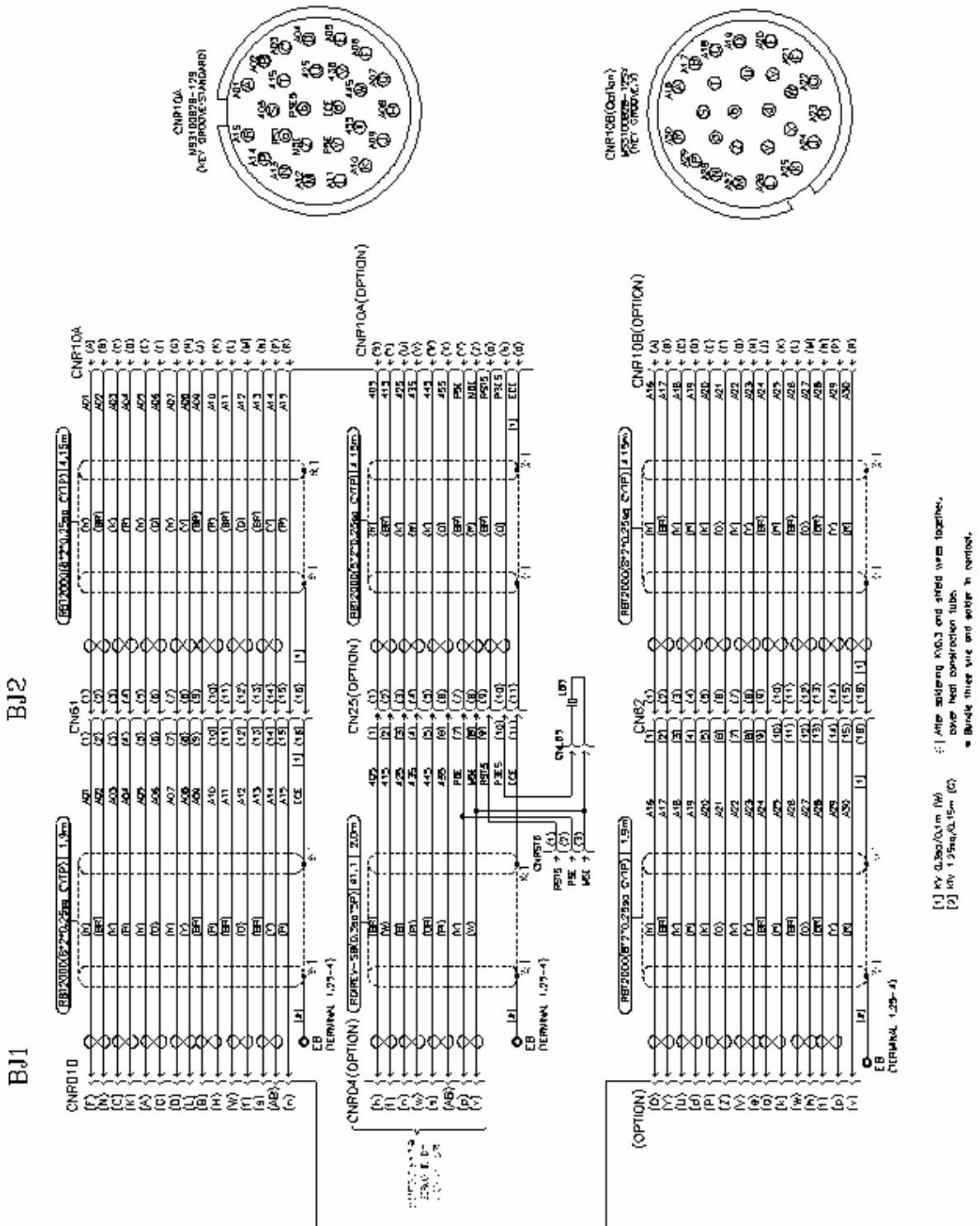

Fig 8.6 Application Wiring Connection

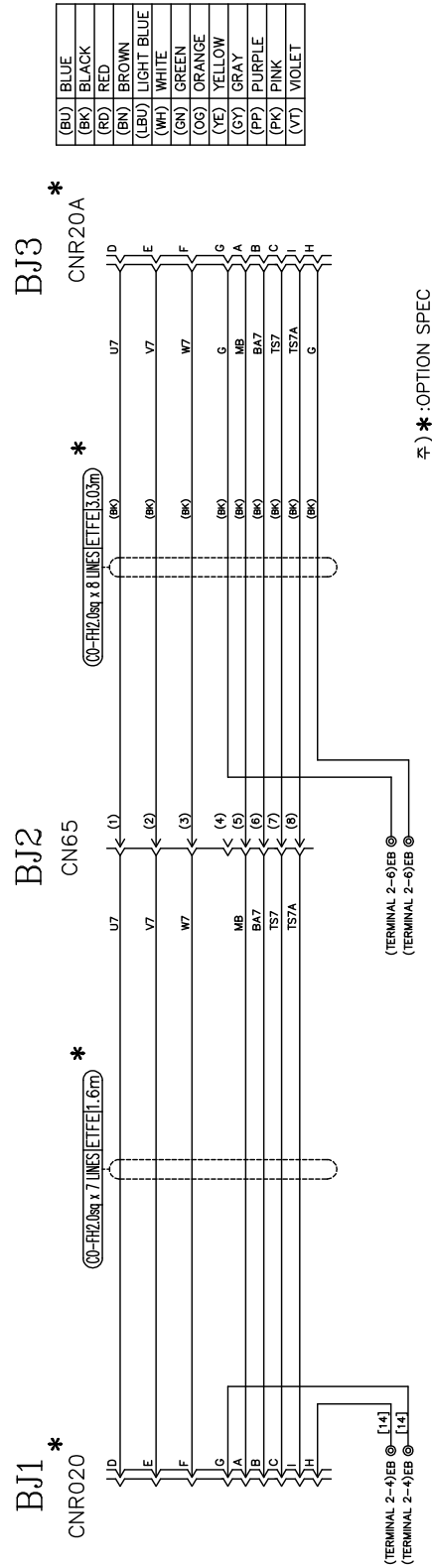

Fig 8.7 Application Wiring Connection No.2

- Bundle wires & pressure in contact.
  - Bundle two wires & solder in contact.
- [14] UL1015 14AWG /0.2m(G/Y)



● **Head Office**

1, Jeonha-Dong, Dong-Gu, Ulsan, Korea  
TEL : 82-52-230-7901 Ex 11 / FAX : 82-52-230-7900

● **Seoul Office**

140-2, Gye-Dong, Jongno-Gu, Seoul, Korea  
TEL : 82-2-746-4711 Ex 5 / FAX : 82-2-746-4720

● **Suwon Office**

537-3, Yeongdeok-Ri, Giheung-Eup, Yongin-Si, Kyenggi-Do, Korea  
TEL : 82-31-205-4713 / FAX : 82-31-205-3200

● **Daegu Office**

223-5, Bumeo 2-Dong, Susung-Gu, Daegu, Korea  
TEL : 82-53-746-6232 Ex 3 / FAX : 82-53-746-6231

● **Cheonan Office**

355-15, Daga-Dong, Cheonan, Chungnam, Korea  
TEL : 82-41-576-4294 Ex 5 / FAX : 82-41-576-4296

● **Gwangju Office**

415-2, Nongsung-Dong, Seo-Gu, Gwangju, Korea  
TEL : 82-62-363-5272 / FAX : 82-62-363-5273

● **본사**

울산광역시 동구 전하동 1 번지  
TEL : 052-230-7901~11 / FAX : 052-230-7900

● **서울 사무소**

서울특별시 종로구 계동 140-2 번지  
TEL: 02-746-4711~5 / FAX : 02-746-4720

● **수원 사무소**

경기도 용인시 기흥읍 영덕리 537-3 번지  
TEL: 031-205-4713 / FAX : 031-205-3200

● **대구 사무소**

대구광역시 수성구 범어 2 동 223-5 번지  
TEL : 053-746-6232~3 / FAX : 053-746-6231

● **천안 사무소**

충남 천안시 다가동 355-15 번지  
TEL : 041-576-4294~5 / FAX : 041-576-4296

● **광주 사무소**

광주광역시 서구 농성동 415-2 번지  
TEL : 062-363-5272 / FAX : 062-363-5273